



METER SOCKETS

CTS Series – 20 Amp, 600 Volts	4
CTS Series – 20 Amp, 600 Volts, c/w Test Switch Compartment	5
SH Series – 100 Amp, 600 Volts, Shallow	6
SE Series – 100 Amp, 600 Volts, King Size	7
SFC Series – 100 Amp, 7 Jaw, Polyphase	8
3 Phase – 4 Wire Meter Sockets	
JA Series – 100 Amp, Socket & Breaker	9
SFVC Series – 100 Amp, Double Metering, Demand & Watt Hour Meter	10
SD Series – 100 Amp, Multi Position	11
SDC Series – 100 Amp, Multi Position	12
200 Amp Mains, c/w Blank Compartment	
MCC Series – 100 Amp, Multi Position	13
200 Amp Mains, Compression Studs 1/2"	
SLC Series – 200 Amp, 600 Volts, Lay In Lugs	14
EK Series – 200 Amp, 600 Volts	16
Compression Studs	
MSC Series – 200 Amp, 600 Volts	17
STC Series – 200 Amp, 7 Jaw Polyphase	18
3 Phase – 4 Wire Meter Sockets	
JA Series – 200 Amp, Socket, c/w Breaker	19
H22R Series – 2 Position, 200 Amp	20
HC22R Series – 200 Amp, Mains	21
c/w Blank Compartment	
MSC Series – 200 Amp, Multi Position	22
1/2" Studs, 200 Amp Mains, c/w blank Wiring Compartment	
H40 Series – 200 Amp, Multi Position	23
400 Amp Mains	
HC40 Series – 200 Amp, Multi Position	24
Stud Type 400 Amp Mains c/w Blank Wiring Compartment	
MSC Series – 200 Amp, Multi Position	25
Stud Type, 400 Amp Mains c/w Blank Wiring Compartment	
MSC Series – 200 Amp, Multi Position	26
Stud Type, 400 Amp Mains c/w Blank Wiring Compartment, 2 Blanks	
STVC Series – 200 Amp, Double Metering	27
Demand & Watt Hour Meter	
CT4 Series – 400 Amp, Meter Socket	28
120/240 volt, Single Phase	
CT4 Series – 400 Amp, Meter Socket	29
120/240 volt, Single Phase	
Panel Mounting Socket	30
ACCESSORIES	
Hubs/Plates	31
Sealing Rings/Covers	32
Seals & Jumper Bars	33
5th Jaw Kits	34
Replacement Block Assemblies	35
Typical Wiring Diagrams	36
Meter Sockets Cross Reference List	37



METER
SOCKETS

MAST AND
ACCESSORIES

POLELINE &
GROUNDING

COMMERCIAL
ENCLOSURES

INDUSTRIAL
ENCLOSURES

BUSDUCT

SWITCHES
DOUBLE THROW

Ontario Hydro / Scarborough Enclosures –	37
MAST AND ACCESSORIES	
2 1/2" Bungalow Service	39 – 42
Mast Kits – Ontario	43
Mast Kits – New Brunswick, Nova Scotia	44
Mast Kits – Newfoundland, British Columbia	45
Mast Kits – Alberta, Quebec	46
Wall Racks, Mast Guy Kits	47
Grounding Plates	48
POLELINE AND GROUNDING	
Galvanized Steel –	
Groundrods & Accessories	50
Copper Clad Groundrods and Connectors	51
Bolts/Washers	52
Steel Clevises	53
Wedge Grips/Insulator	54
Bolts & Guy Wire	55
U-Cable Guards, Straps, Throat Clips	56
ENCLOSURES, CABINETS & BOXES	
Commercial Enclosures	57
Type "D" & Pull Boxes	58
Type "E", "C" Boxes, Type "T" Cabinets	59
Splitter Troughs Nema 1	60
Splitter Boxes 600V & Nema 3	61
Splitter Blocks	62
Standoff Insulators	63
Meter Cabinets	64
Lay-in Duct Nema 1	65
Continuous Busbar Troughs	66
Custom Made Nema 1	
Continuous Busbar Trough Connectors	67
Nema 1 Enclosures	68
INDUSTRIAL ENCLOSURES	
Small Oil, Dust & Watertight Enclosures	70
Large Oil, Dust & Watertight	71
Wiring Troughs	72
Pushbutton Enclosures	73
Custom Cabinetry	74
Industrial Bus Duct	75
FLEX-A-POWER	
Flex-A-Power	76 – 78
Bus Duct & Accessories – 3 Phase, 3 Wire	79
Bus Duct & Accessories – 3 Phase, 4 Wire	80
Flex-A-Power – Dimension Data	81
FLEX-A-PLUGS	
FE Series	82
FSF Series	83
Flex-A-Power – Assembly Instructions	84
INDUSTRIAL SAFETY SWITCHES	
600V, Heavy Duty	86 - 87

Meter Sockets



METER
SOCKETS



METER SOCKETS & ACCESSORIES

CTS Series



20 AMP - 600 VOLTS Transformer Rated

CATALOGUE #	DESCRIPTION	WEIGHT
CTS409PW	5 Jaw with circuit closing left side for "CMS" applications*	5 lbs.
CTS459PW	5 Jaw with circuit closing left side for 4 Jaw application**	5 lbs.
CTS408PW	4 Jaw with circuit closing on left and right side	5 lbs.
CTS429PW	4 Jaw with circuit closing on left and right side	5 lbs.

- Transformer rated for services over 200 Amps
- CSA approved for copper only
- CSA enclosure 3
- Range No. 14 - No. 8 CU
- Circuit closing feature to short out current transformer upon removal of meter
- Pole mountable
- Central metering systems

*5th Jaw in 9 O'clock position, meets 2004 Hydro One code
 **5th Jaw in 6 O'clock position, Dummy Jaw in lower right hand position
 For use on 4 Jaw CMS applications

KNOCKOUT CODE	CONDUIT SIZE
C	1", 1 1/4", 1 1/2"
A	1/2", 1", 1 1/4"
B	1", 1 1/4"



**CTS409PW
CTS459PW**

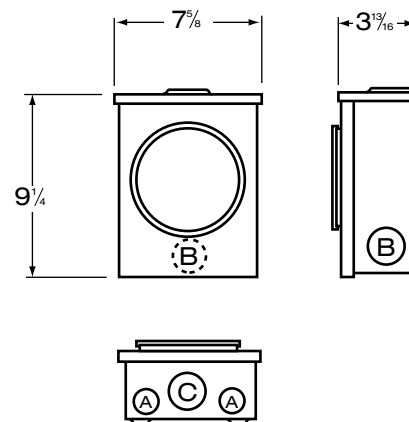

CTS Series

20 AMP - 600 VOLTS c/w Test Switch Comp.



CATALOGUE #	DESCRIPTION	WEIGHT
CTS400PW	4 Jaw	24 lbs.
CTS500PW	5 Jaw - 5th Jaw in 6 O'clock position	24 lbs.
CTS405PW	5 Jaw - for 4th Jaw application*, 5th Jaw at 9 O'Clock position	24 lbs.
CTS800PW	8 Jaw	26 lbs.
CTS130PW	13 Jaw	26 lbs.
CTS139PW	13 JAW - with by-pass	26 lbs.
CTS130PW-TS	13 JAW c/w 10 pole test switch	30 lbs.
CTS400PW-TS	4 JAW -c/w 4 pole test switch	30 lbs.

- Transformer rated for services over 200 Amps
- CSA enclosure 3
- CSA approved for copper only
- Conductor range for No. 14 - No. 8 CU
- Meter socket with compartment for test switches or test blocks
- Bottom cover is lockable and sealable

KNOCKOUT CODE	CONDUIT SIZE
N	3/4", 1", 1 1/4"

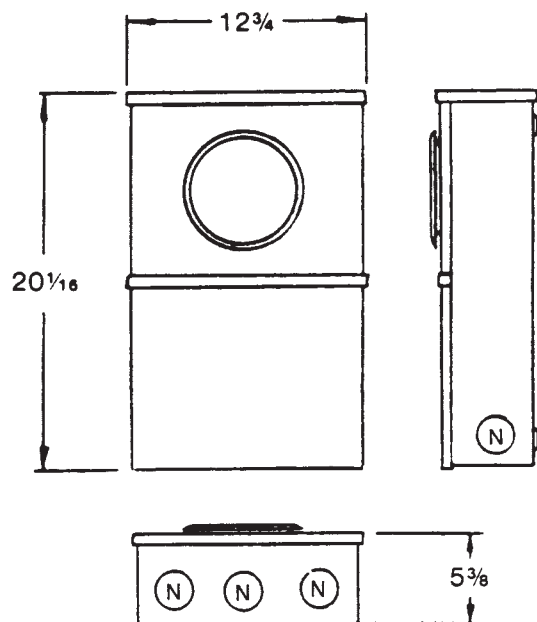

SH Series



100 AMP - 600 VOLTS Shallow

CATALOGUE #	DESCRIPTION	WEIGHT
SH400PW	c/w hub closure plate, overhead/underground	5 lbs.
SH400JW	Overhead c/w 1 1/4" hub	5 lbs.
SH400BW	Overhead twin hub opening c/w 2 - 1 1/4" hubs	6 lbs.
SH400BP	Overhead twin hub opening c/w closure plates	5 lbs.
SH400MW	c/w mast coupler	5 lbs.
SH400TW	Underground - blank top	5 lbs.
SH400KO	Overhead with knockout on top (indoor)	5 lbs.

- CSA weatherproof enclosure 3
- Approved conductor range No.6 - No.2CU
- Copper only
- Insulated neutral available upon request

- Field adaptable Accessories
- 5th Jaw at 9 O'clock - SXX503

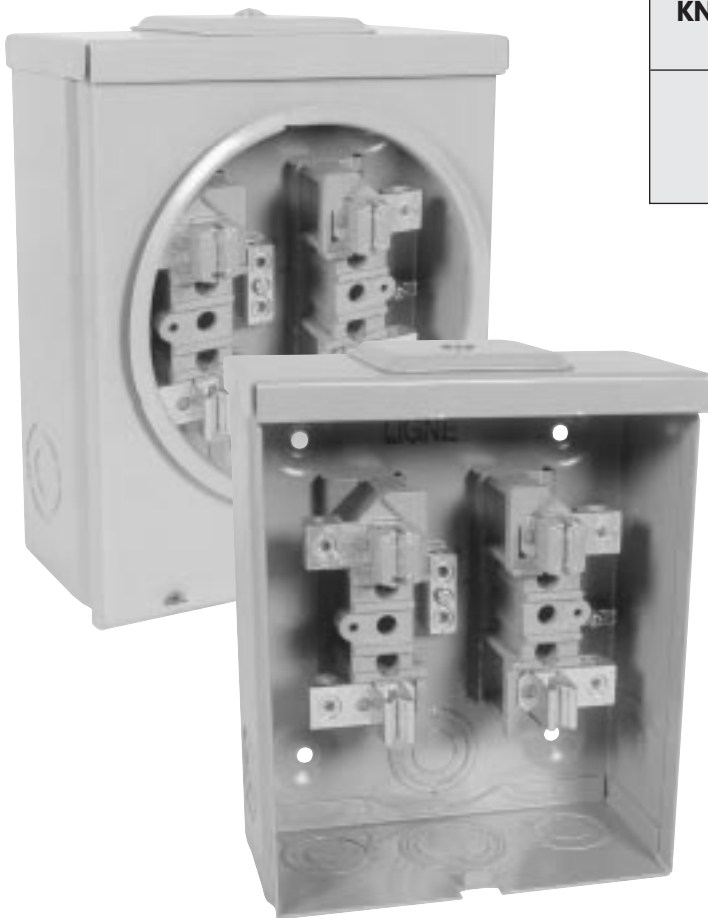

KNOCKOUT CODE	CONDUIT SIZE
A	1/2", 1", 1 1/4"
B	1", 1 1/4"
C	1", 1 1/4", 1 1/2"

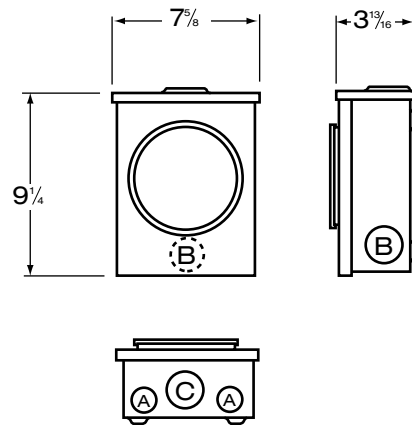

SE Series

100 AMP - 600 VOLTS King Size



CATALOGUE #	DESCRIPTION	WEIGHT
SE400PW	Overhead, hub opening, hub plate not included	8 lbs.
SE400JW	Overhead c/w 1 1/4" hub	8 lbs.
SE400TW	Underground blank top	8 lbs.
SE400RW	Combination overhead / underground	8 lbs.
SE400BW	Overhead c/w twin 1 1/4" hubs	9 lbs.
SE400BP	Overhead twin closure plates not included	8 lbs.
SE420RW	Combination OH/UG c/w water heater lugs	8 lbs.

- Conductor range No. 6 - 1/0 AWG CU/AL
- CSA weatherproof enclosure 3
- Approved for copper or aluminum
- For extra ground lug on neutral add suffix NB - Used in New Brunswick

- Field adaptable accessories
- 5th Jaw at 9 O'clock - **SXK503**
- Insulated neutral - **ink 100**
- 5th Jaw at 6 O'clock - **ink 105**

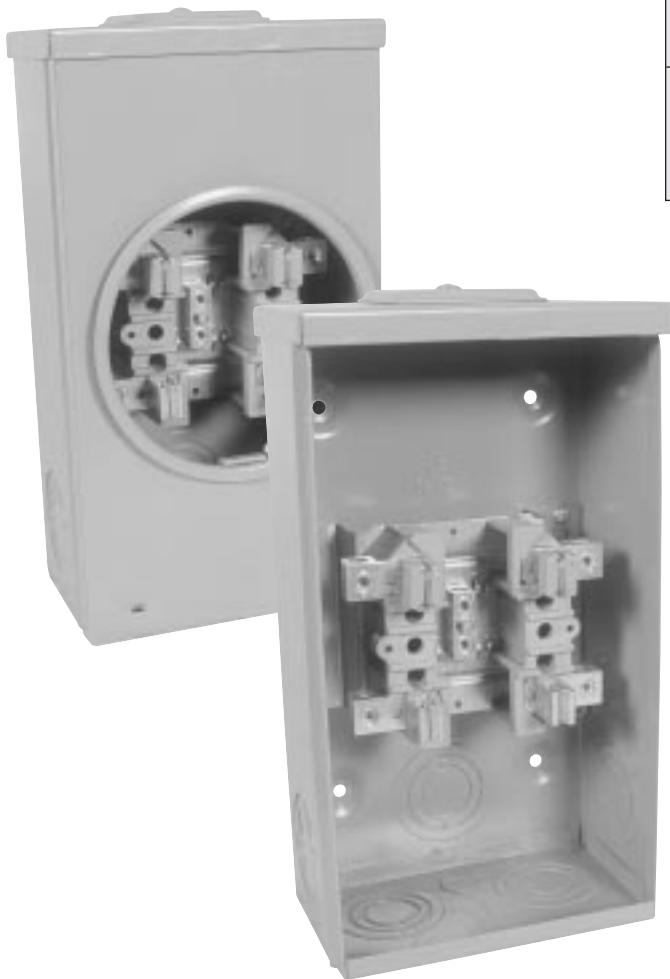

KNOCKOUT CODE	CONDUIT SIZE
AA	1/2"
D	1 1/4", 1 1/2", 2"
E	1", 1 1/4", 1 1/2", 2"

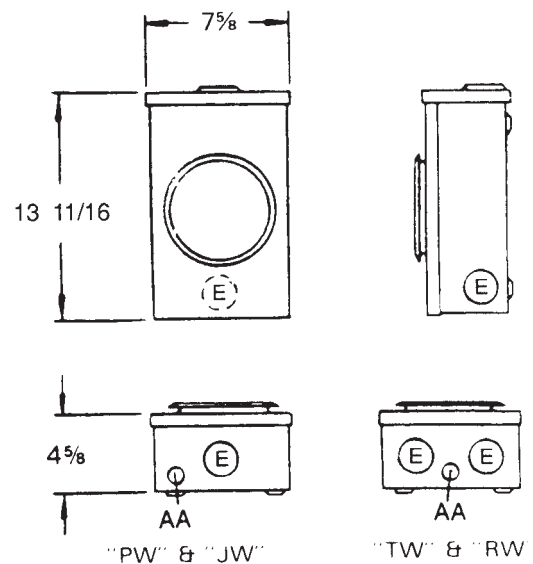

SFC Series



100 AMP - 7 JAW Polyphase 3 PH - 4 Wire Meter Sockets

CATALOGUE #	DESCRIPTION	ENCLOSURE SIZE H X W X D	WEIGHT
SFC700PW	7 Jaw overhead c/w hub closure plate	15 ³ / ₈ " x 8 ⁵ / ₈ " x 5"	12 lbs.
SFC703PW	as above, c/w insulated neutral	15 ³ / ₈ " x 8 ⁵ / ₈ " x 5"	12 lbs.
SFC800PW	8 Jaw - overhead	15 ³ / ₈ " x 8 ⁵ / ₈ " x 5"	12 lbs.
SFC700RW	7 Jaw combination overhead/underground	15 ³ / ₈ " x 8 ⁵ / ₈ " x 5"	12 lbs.

- 100 Amp, 600 VOLT
- CSA enclosure 3
- CSA approved for copper or aluminum
- Conductor range #6 - 1/0 AWG CU/AL

- Order "SXC" hubs separately
- Insulated neutral can be field added
"INK 100"

KNOCKOUT CODE	CONDUIT SIZE
AA	1/2"
G	1 ¹ / ₄ ", 1 ¹ / ₂ ", 2", 2 ¹ / ₂ "

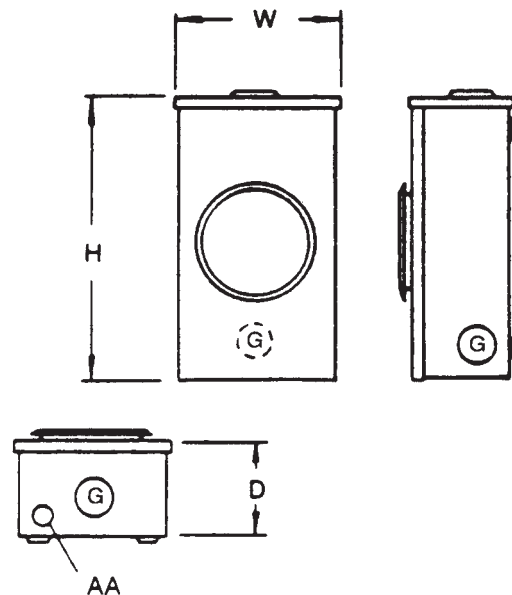

JA Series



100 AMP SOCKET & BREAKER

Breaker not included, Service Entrance Approved

CATALOGUE #	DESCRIPTION	ENCLOSURE SIZE H X W X D	WEIGHT
JA400RW	Conductor range #6 - 1/0 AWG CU/AL (combination)*†	22 ³ / ₈ " x 8 ¹ / ₄ " x 3 ³ / ₄ "	20 lbs.
JA400RWT	As above, c/w 100 amp 2 pole breaker	22 ³ / ₈ " x 8 ¹ / ₄ " x 3 ³ / ₄ "	21 lbs.
JA400PW	Conductor range #6 - 1/0 AWG CU/AL overhead	22 ³ / ₈ " x 8 ¹ / ₄ " x 3 ³ / ₄ "	20 lbs.
JA000PW	Conductor range #6 - #3 copper only (overhead)*†	18 ¹ / ₄ " x 7 ⁵ / ₈ " x 3 ³ / ₄ "	15 lbs.
JA000PWSD	As above but adapted to take SQ D breaker only - "QO" series	18 ¹ / ₄ " x 7 ⁵ / ₈ " x 3 ³ / ₄ "	15 lbs.

- 4 Jaw - 100Amp - 120/240 VOLT
- Combination meter socket & circuit breaker
- CSA weatherproof enclosure 3
- Suitable for mobile homes, farm services, trailers, temporary services, etc.
- JA000 used with the following makes of breakers: Westinghouse - "BR"
ITE - "Q"
CGE - "THQAL"

*Breaker not included (sold separately)
†Select from table below
- Plug-in circuit breakers fully magnetic
- Use SXX503 for 5th Jaw at 9 O'clock

KNOCKOUT CODE	CONDUIT SIZE
A	1/2", 1", 1 1/4"
C	1", 1 1/4", 1 1/2"
E	1", 1 1/4", 1 1/2", 2"

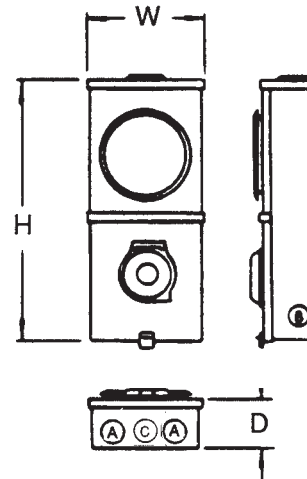

SINGLE POLE

CAT. NO.	AMPS
MP115	15
MP120	20
MP130	30
MP140	40
MP150	50

DOUBLE POLE

CAT. NO.	AMPS
MP215	15
MP220	20
MP230	30
MP240	40
MP250	50

DOUBLE POLE

CAT. NO.	AMPS
MP260	60
MP270	70
MP211	100

SFVC Series



100 AMP - DOUBLE METERING Demand & Watt Hour Meter

CATALOGUE #	DESCRIPTION	WEIGHT
SFVC503PW	5 Jaw - 6 O'clock c/w insulated neutral and adapter plate HD2025	26 lbs.
SFVC703PW	7 Jaw - c/w insulated neutral and adapter plate HD2025	30 lbs.

- Supplied factory based - series connection
- CSA weatherproof enclosure 3
- 100 Amps - 600 VOLTS
- Conductor range #6-1/0 AWG CU/AL
- This is not a multi-position meter socket

- Order "HD" series hubs separately

KNOCKOUT CODE	CONDUIT SIZE
M	2", 2 1/2", 3"
AA	1/2"

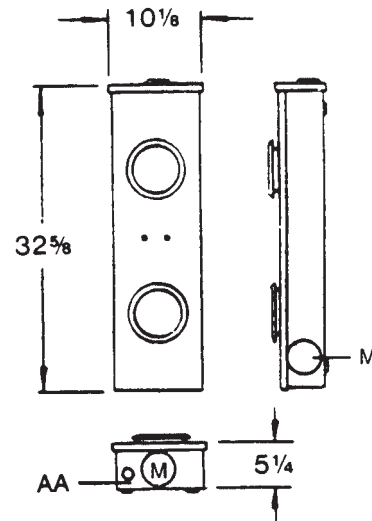

SD Series

100 AMP - MULTI POSITION



CATALOGUE #	DESCRIPTION	METER POSITIONS	ENCLOSURE SIZE A X B X C	WEIGHT
SD220PW	2 gang, 200 Amp main, 100 Amp per position	2	15" x 12" x 5"	20 lbs.
SD320PW	3 gang, 200 Amp main, 100 Amp per position	3	22 ¹ / ₂ " x 12" x 5"	28 lbs.
SD420PW	4 gang, 200 Amp main, 100 Amp per position	4	30" x 12" x 5"	36 lbs.
SD520PW	5 gang, 200 Amp main, 100 Amp per position	5	37 ¹ / ₂ " x 12" x 5"	44 lbs.
SD620PW	6 gang, 200 Amp main, 100 Amp per position	6	45" x 12" x 5"	52 lbs.
SD220PWBC	1 - 3" KO in bottom	2	17 ¹ / ₂ " x 15" x 5"	23 lbs.

- Factory bussed - 200 Amp Mains
- 2 - 6 position horizontal
- 4 Jaw meter sockets
- 100 Amp - 600 VOLTS per position
- CSA enclosure 3
- Approved conductor range:
Line No. 6-250 MCM CU/AL
Load No. 6-1/0 AWG CU/AL
- Approved for overhead or underground use

- Field adaptable accessories
- 5th Jaw at 9 O'clock - SXK503
- For overhead order "SXC" hub separate
- Add suffix "RH" for right hand entry

KNOCKOUT CODE	CONDUIT SIZE
D	1 ¹ / ₄ ", 1 ¹ / ₂ ", 2"
G	1 ¹ / ₄ ", 1 ¹ / ₂ ", 2", 2 ¹ / ₂ "
AA	1 ¹ / ₂ "

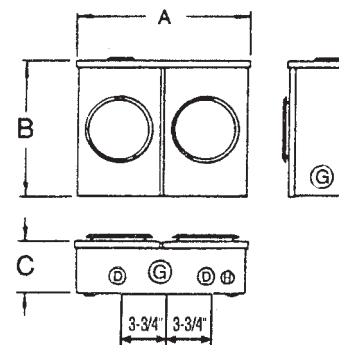

SD220 Conversion Kit

To convert existing SD220PW to a two load single meter, meter socket ST911 - OH

SDC Series



100 AMP - MULTI POSITION 200 Amp Mains c/w Blank Compartment

METER
SOCKETS

CATALOGUE #	DESCRIPTION	METER POSITIONS	ENCLOSURE SIZE A X B X C	WEIGHT
SDC220PW	c/w blank compartment on left side - 2 gang	2	22 ¹ / ₂ " x 12" x 5"	24 lbs.
SDC320PW	c/w blank compartment on left side - 3 gang	3	30" x 12" x 5"	32 lbs.
SDC420PW	c/w blank compartment on left side - 4 gang	4	37 ¹ / ₂ " x 12" x 5"	40 lbs.
SDC520PW	As Above - 5 gang	5	45" x 12" x 5"	47 lbs.
SDC620PW	As Above - 6 gang	6	52" x 12" x 5"	56 lbs.
SDC220PWBC	1 - 3" KO in bottom	2	26 ¹ / ₄ " x 15" x 5"	32 lbs.

- Factory Bussed - 200 Amp mains
- 2 - 4 position horizontal
- 4 Jaw meter sockets
- 100 Amp - 600 VOLTS per position
- All units above c/w 3" KO for BC
- Approved conductor range:
Line No. 6-250 MCM CU/AL
Load No. 6-1/0 AWG CU/AL
- Approved for overhead or underground use

- Field adaptable accessories
- 5th Jaw at 9 O'clock - SXK503
- For overhead "SXC" hub
- Add "RH" if right hand entry required, contact Sales Office for pricing

KNOCKOUT CODE	CONDUIT SIZE
D	1 ¹ / ₄ ", 1 ¹ / ₂ ", 2"
F	1, 1 ¹ / ₄ ", 1 ¹ / ₂ ", 2", 2 ¹ / ₂ ", 3"
AA	1 ¹ / ₂ "

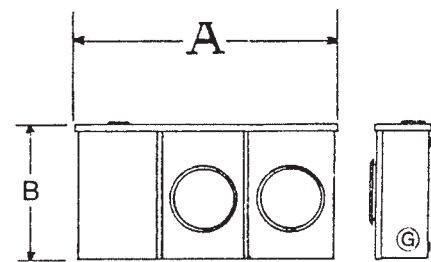
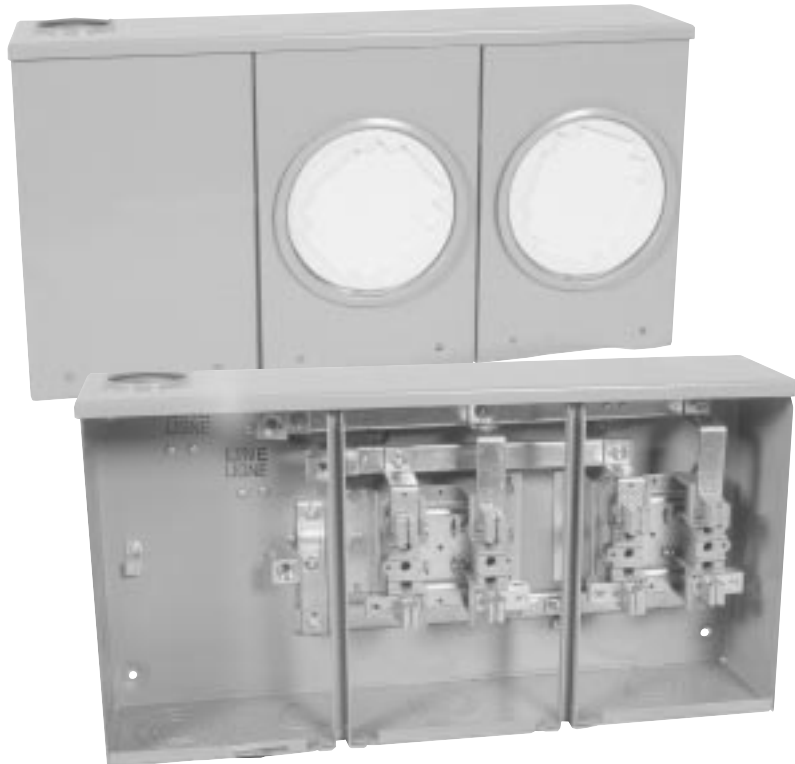

Extra Wing Compartment

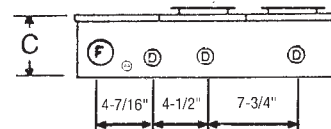



100 AMP - MULTI POSITION 200 Amp Mains, Compression Studs 1/2"

CATALOGUE #	DESCRIPTION	METER POSITIONS	ENCLOSURE SIZE A X B X C	WEIGHT
MCC220TW	c/w blank compartment on left side - 2 gang	2	22 ¹ / ₂ " X 12" X 5"	24 lbs.
MCC320TW	c/w blank compartment on left side - 3 gang	3	30" X 12" X 5"	32 lbs.
MCC420TW	c/w blank compartment on left side - 4 gang	4	37 ¹ / ₂ " X 12" X 5"	40 lbs.
MCC520TW	c/w blank compartment on left side - 5 gang	5	45" x 12" x 5"	47 lbs.
MCC620TW	c/w blank compartment on left side - 6 gang	6	52" x 12" x 5"	56 lbs.

- CSA enclosure 3
- 1/2" Studs on line side
- Conductor range load size No. 6-1/0 AWG
- Compression studs on line side
- For underground use only
- Prebussed from main lugs to each position

KNOCKOUT CODE	CONDUIT SIZE
D	1 ¹ / ₄ ", 1 ¹ / ₂ ", 2"
F	1, 1 ¹ / ₄ ", 1 ¹ / ₂ ", 2", 2 ¹ / ₂ ", 3"
AA	1 ¹ / ₂ "

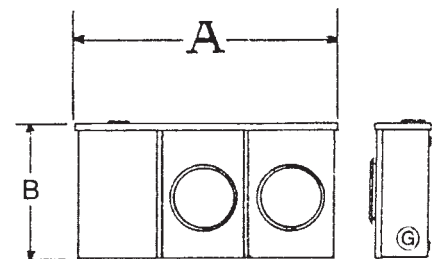
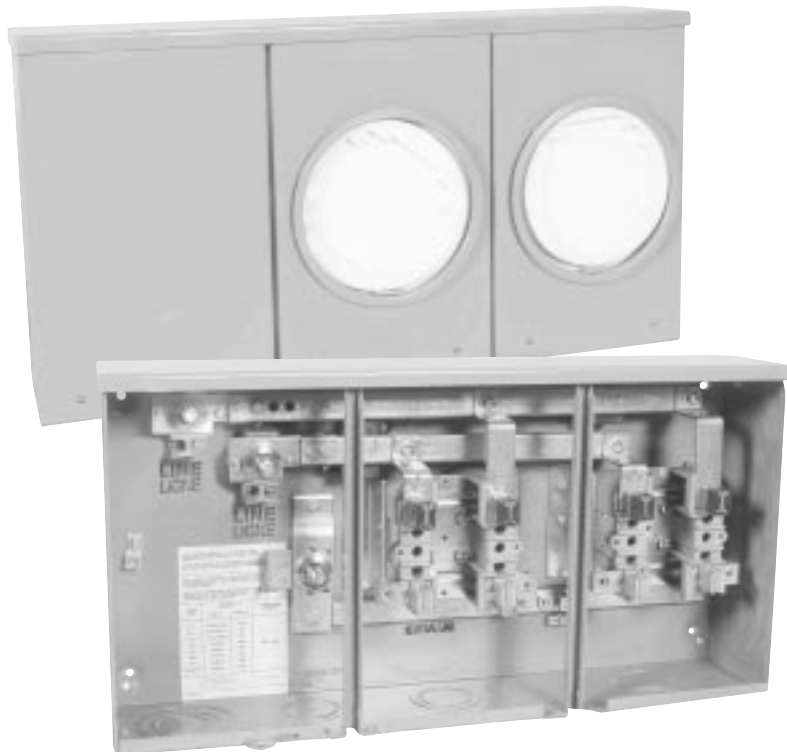

Extra Wing Compartment

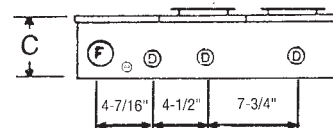

SLC Series

NEW Design



200 AMP - 600 VOLTS Lay in Lugs

CATALOGUE #	DESCRIPTION	ENCLOSURE SIZE H X W X D	WEIGHT
SLC400RW	Comb. overhead, underground	18" x 12" x 5"	17 lbs.
SLC420RW	Comb. overhead, underground, c/w water heater lugs	18" x 12" x 5"	17 lbs.
SLC400RWBC	Comb. OH/UG for British Columbia	18" x 12" x 5"	17 lbs.
SLC402RW	Comb. OH, UG, with twin 1/0 AWG on load side. Also approved by BC Hydro.	18" x 12" x 5"	17 lbs.

- CSA enclosure 3
- Conductor range No. 6-250 MCM CU/AL
- Lay in type connectors makes wiring quick and easy

KNOCKOUT CODE	CONDUIT SIZE
AA	1/2"
G	1 1/4", 1 1/2", 2", 2 1/2"
F	1", 1 1/4", 1 1/2", 2", 2 1/2", 3"

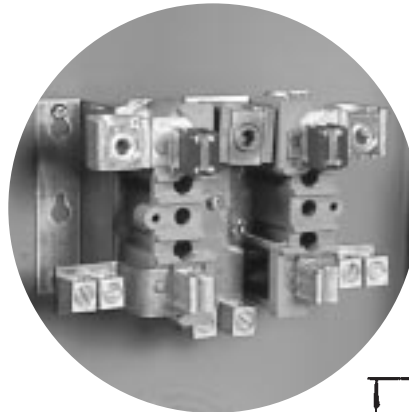

SLC402RW

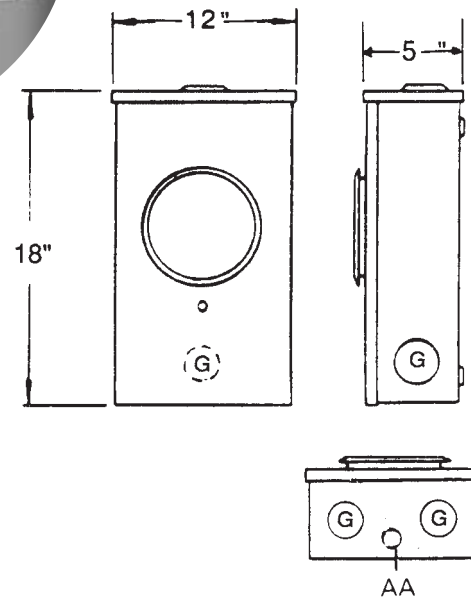

EK Series

THE "NEW" 200 AMP METER SOCKET LINE Plastic Blocks Made of Noryl SE - 1



METER
SOCKETS



Lay - in neutral can be used
with unbroken neutral wire



c/w ground lug on neutral
(for New Brunswick)
Part #ZMS7051433 -
Ground Neutral Assembly

Add suffix "NS" to all meter sockets used
in New Brunswick, ie EK400PNS

EK Series

200 AMP - 600 VOLTS



CATALOGUE #	DESCRIPTION	ENCLOSURE TYPE	ENCLOSURE SIZE	WEIGHT
EK400P	Overhead c/w hub plate	A	15 ³ / ₈ " x 8 ⁵ / ₈ " x 5"	12 lbs.
EK400L	Overhead c/w 2" hub	A	15 ³ / ₈ " x 8 ⁵ / ₈ " x 5"	13 lbsca.
EK400D	Overhead c/w 2-2" hubs	A	15 ³ / ₈ " x 8 ⁵ / ₈ " x 5"	14 lbs.
EK400DP	Overhead c/w 2 hub plates, twin openings	A	15 ³ / ₈ " x 8 ⁵ / ₈ " x 5"	13 lbs.
EK400M	Overhead c/w master coupler	A	15 ³ / ₈ " x 8 ⁵ / ₈ " x 5"	13 lbs.
EK400T	Underground	B	15 ³ / ₈ " x 8 ⁵ / ₈ " x 5"	12 lbs.
EK400R	Comb. OH/UG approved for BC as well	D	18" x 10 x 5 ³ / ₈ "	14 lbs.
EK400RO	Comb. OH/UG, oversize enclosure	F	18" x 12" x 5"	15 lbs.
E400RO	Comb. OH/UG straight lugs on line side	F	18" x 12" x 5"	15 lbs.
EK400TO	Underground oversize enclosure	F	18" x 12" x 5"	15 lbs.
EK400ROW	Comb. OH/UG c/w water heater lugs	F	18" x 12" x 5"	15 lbs.
EK400ROBC	Oversize enclosure for BC only	E	18" x 12" x 5 ³ / ₈ "	15 lbs.

- CSA enclosure 3
- Barrel type connectors angled at 45°
- Conductor range No. 6 -250 MCM CU/AL
- Lay-in neutral (can be used with unbroken neutral wire)
- Add suffix NS for ground lug on neutral for New Brunswick only

- Field adaptable accessories
- 5th Jaw at 9 O'clock "SXK503"
- 5th Jaw at 6 O'clock "INK501"
- Insulated neutral INK200

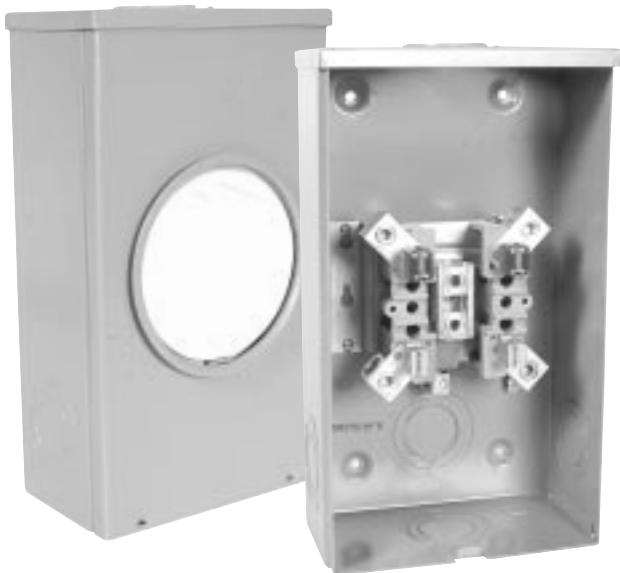

KNOCKOUT CODE	CONDUIT SIZE
AA	1/2"
G	1 ¹ / ₄ ", 1 ¹ / ₂ ", 2", 2 ¹ / ₂ "
F	1", 1 ¹ / ₄ ", 1 ¹ / ₂ ", 2", 2 ¹ / ₂ ", 3"

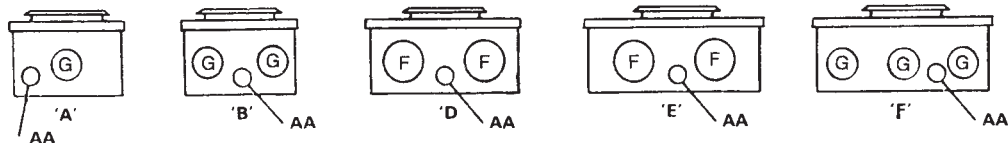
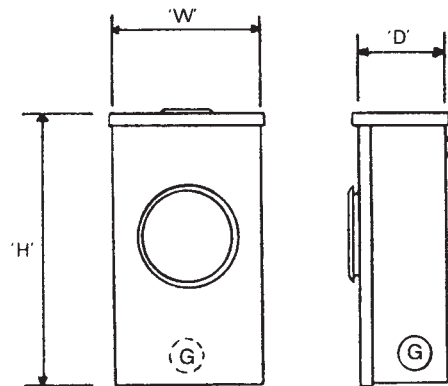



200 AMP - 600 VOLTS Compression Studs

CATALOGUE #	DESCRIPTION	ENCLOSURE SIZE H X W X D	WEIGHT
MSC400TW	Underground c/w 1/2" Compression studs, 2 1/2" KO'S x 3	18" x 12" x 5"	17 lbs.
MSC400TW3	Underground c/w 1/2" Compression studs, 3" KO'S x 2 Available upon request	18" x 12" x 5 3/8"	18 lbs.
MSC400TW-SF	Underground with 1/2" studs c/w sub feed lugs 1/0-14	18" X 12" X 5"	17 lbs.

- CSA enclosure 3
- Conductor range load size No. 6 - 250 MCM CU/AL
- 1/2" line studs provided for compression type wire connectors
- For underground use only

- For water heater lugs order *SXC022* - see accessories
- For North York dead end assembly order *SXCONY* - see accessories

KNOCKOUT CODE	CONDUIT SIZE
AA	1/2"
G	1 1/4", 1 1/2", 2", 2 1/2"
F	1", 1 1/4", 1 1/2", 2", 2 1/2", 3"

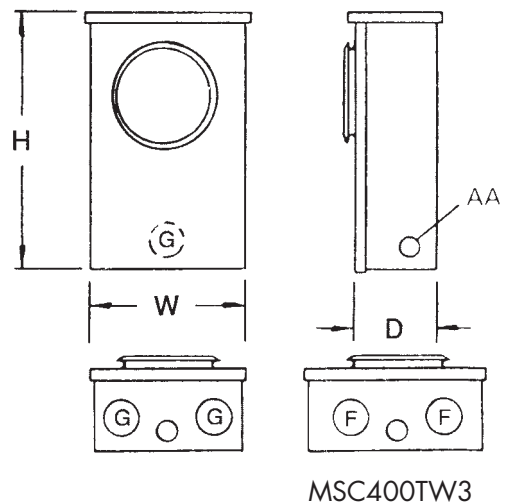

STC Series



200 AMP - 7 JAW Polyphase 3PH - 4 Wire Meter Sockets

CATALOGUE #	DESCRIPTION	ENCLOSURE SIZE H X W X D	WEIGHT
STC700PK	Overhead hub opening	21 ¹ / ₂ " x 10 ¹ / ₈ " x 5 ³ / ₈ "	21 lbs.
STC703PK	Overhead hub opening c/w insulated neutral	21 ¹ / ₂ " x 10 ¹ / ₈ " x 5 ³ / ₈ "	21 lbs.
STC700RK	Combination underground/overhead	21 ¹ / ₂ " x 12" x 5 ³ / ₈ "	22 lbs.
STC703RK	Combination underground/overhead c/w insulated neutral	21 ¹ / ₂ " x 12" x 5 ³ / ₈ "	22 lbs.

- 200 Amp, 600 VOLT
- CSA enclosure 3
- CSA approved for copper or aluminum
- Conductor range #6 -250 MCM CU/AL
- Comes c/w HUB closure adapter plate HD2025

- For overhead installations order "HD" hubs separately
- Field adapted insulated neutral "INK200"



KNOCKOUT CODE	CONDUIT SIZE
AA	1/2"
K	2", 2 ¹ / ₂ ", 3"

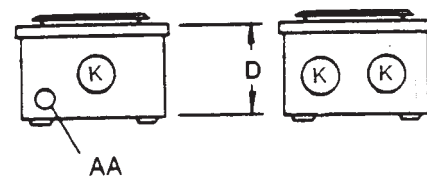
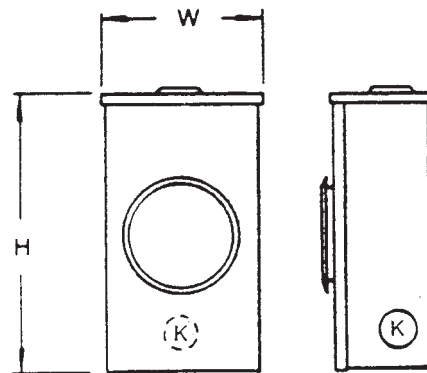

For permanent by-pass
use JC6B jumper cover

JA Series



200 AMP SOCKET c/w Breaker

CATALOGUE #	DESCRIPTION	ENCLOSURE SIZE H X W X D	WEIGHT
JA402P	c/w 200 Amp breaker, 4 jaw, 120/240 VOLTS, single phase, 3 wire	30" x 10 ¹ / ₄ " x 5 ¹ / ₄ "	25 lbs.
JA402PSD-LB	as above, less breaker (will accomodate square D breaker only)	30" x 10 ¹ / ₄ " x 5 ¹ / ₄ "	24 lbs.
JA402PSD	c/w 200 amp square D breaker	30" x 10 ¹ / ₄ " x 5 ¹ / ₄ "	25 lbs.

- 200 Amp - 120/240 VOLT
- Combination meter socket & circuit breaker
- CSA enclosure 3
- Conductor range #6 - 250 MCM CU/AL
- Suitable for temporary service, farm service, trailers, recreational parks, commercial and residential locations.
- Service entrance rated

- Also available with 125 Amp breaker or 150 Amp breaker upon request
- Also available less breaker

KNOCKOUT CODE	CONDUIT SIZE
G	1 ¹ / ₄ ", 1 ¹ / ₂ ", 2", 2 ¹ / ₂ "

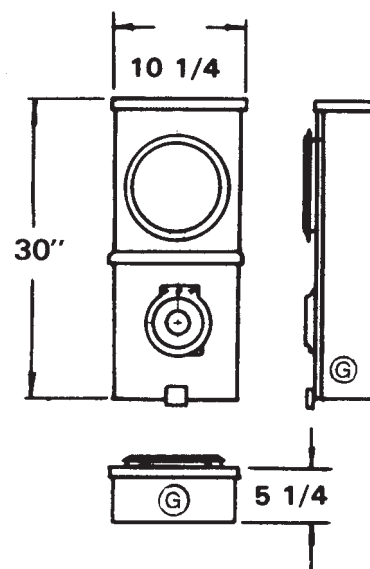

H22R Series



2 POSITION - 200 AMP / POSITION 200 Amp Mains

CATALOGUE #	DESCRIPTION	METER POSITIONS	ENCLOSURE SIZE A X B X C	WEIGHT
H22R	2 gang, 200 Amp main, 200 per position	2	15 ¹ / ₈ " x 5 ³ / ₈ " x 17 ³ / ₄ "	42 lbs.
H23R	3 gang, 200 Amp main, 200 per position	3	15 ¹ / ₈ " x 5 ³ / ₈ " x 26 ¹ / ₂ "	58 lbs.
H24R	4 gang, 200 Amp main, 200 per position	4	15 ¹ / ₈ " x 5 ³ / ₈ " x 35 ¹ / ₄ "	74 lbs.

- Factory Bussed - 200 Amp Mains
- 4 Jaw meter socket
- 200 Amp - 600 Volts per position
- CSA enclosure 3
- Approved conductor range:
Line 6-250 MCM AWG CU/AL
Load No. 6-250 MCM AWG
- Combination OH/UG

- Order "SXC" hubs separate
- Approved for overhead or underground use

KNOCKOUT CODE	CONDUIT SIZE
G	1 ¹ / ₄ ", 1 ¹ / ₂ ", 2", 2 ¹ / ₂ "
AA	1 ¹ / ₂ "
F	1 ¹ / ₄ ", 1 ¹ / ₂ ", 2", 2 ¹ / ₂ ", 3"

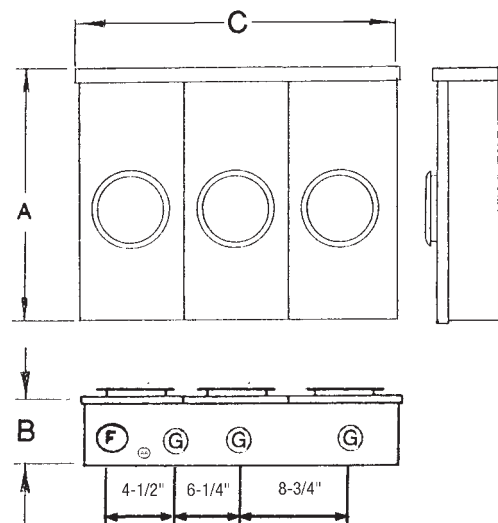

HC22R Series



200 AMP MAINS - 200 AMP / POSITION c/w Blank Compartment

CATALOGUE #	DESCRIPTION	METER POSITIONS	ENCLOSURE SIZE A X B X C	WEIGHT
HC22R	2 gang, 200 Amp main, 200 per position	2	15 ¹ / ₈ " x 5 ³ / ₈ " x 26 ¹ / ₂ "	42 lbs.
HC23R	3 gang, 200 Amp main, 200 per position	3	15 ¹ / ₈ " x 5 ³ / ₈ " x 35 ¹ / ₄ "	58 lbs.
HC24R	4 gang, 200 Amp main, 200 per position	4	15 ¹ / ₈ " x 5 ³ / ₈ " x 44"	74 lbs.

- Blank compartment on left side for underground
- Factory Bussed - 200 Amp Mains
- 4 Jaw meter socket
- 200 Amp - 600 Volts per position
- CSA enclosure 3
- Approved conductor range:
Line 6-250 MCM AWG CU/AL
Load No. 6-250 MCM AWG
- Combination OH/UG
- Used primarily in Cambridge, Ontario

- Order "SXC" hubs separate
- Approved for overhead or underground use
- Use SXC503 for 5th jaw at 9 O'clock

KNOCKOUT CODE	CONDUIT SIZE
G	1 ¹ / ₄ ", 1 ¹ / ₂ ", 2", 2 ¹ / ₂ "
AA	1 ¹ / ₂ "
F	1 ¹ / ₄ ", 1 ¹ / ₂ ", 2", 2 ¹ / ₂ ", 3"

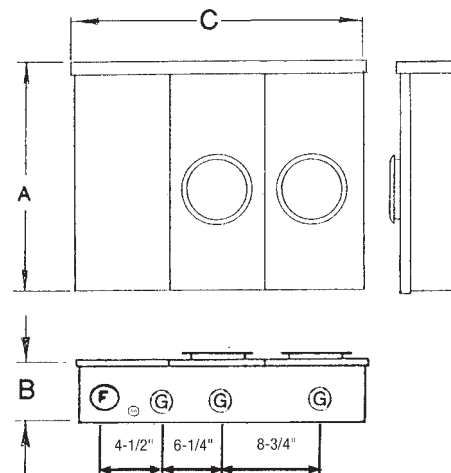

MSC Series



200 AMP - MULTI POSITION 1/2" STUDS 200 Amp Mains c/w Blank Wiring Comp.

CATALOGUE #	DESCRIPTION	METER POSITIONS	ENCLOSURE SIZE A X B X C	WEIGHT
MSC22R	2 gang, c/w 1/2" compression studs	2	15 1/8" x 5 3/8" x 26 1/2"	53 lbs.
MSC23R	3 gang, c/w 1/2" compression studs	3	15 1/8" x 5 3/8" x 35 1/4"	70 lbs.
MSC24R	4 gang, c/w 1/2" compression studs	4	15 1/8" x 5 3/8" x 44"	88 lbs.

- Factory Bussed 200 Amp Mains
- 200 Amp, 600 VOLT per position
- 2 - 4 position horizontal
- 4 Jaw meter sockets
- CSA weatherproof enclosure 3
- Approved conductor range
- Line - studs (two 1/2" per phase)
- Provided for compression type wire connectors
- Load - #6 - 250 MCM CU/AL

- *Underground ONLY*
- *Use SXC022 for water heater lug kit*

KNOCKOUT CODE	CONDUIT SIZE
G	1 1/4", 1 1/2", 2", 2 1/2"
AA	1/2"
F	1 1/4", 1 1/2", 2", 2 1/2", 3"

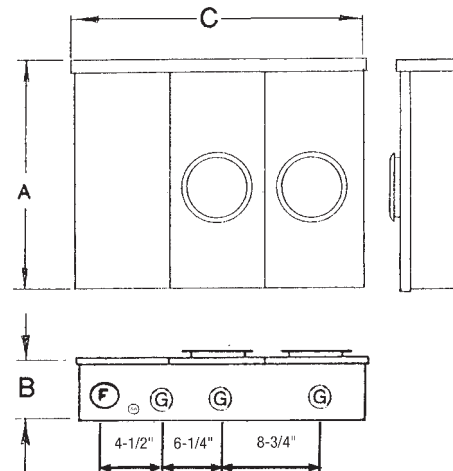

H40 Series

200 AMP - MULTI POSITION 400 Amp Mains



CATALOGUE #	DESCRIPTION	METER POSITIONS	ENCLOSURE SIZE A X B X C	WEIGHT
H42R	2 gang, 400 Amp main, 200 Amp per position	2	22 ³ / ₄ " x 6 ¹ / ₄ " x 18 ⁵ / ₈ "	42 lbs.
H43R	3 gang, 400 Amp main, 200 Amp per position	3	22 ³ / ₄ " x 6 ¹ / ₄ " x 28"	58 lbs.
H44R	4 gang, 400 Amp main, 200 Amp per position	4	22 ³ / ₄ " x 6 ¹ / ₄ " x 37 ³ / ₈ "	74 lbs.
H45R	5 gang, 400 Amp main, 200 Amp per position	5	22 ³ / ₄ " x 6 ¹ / ₄ " x 46 ³ / ₄ "	87 lbs.
H46R	6 gang, 400 Amp main, 200 Amp per position	6	22 ³ / ₄ " x 6 ¹ / ₄ " x 56 ¹ / ₈ "	104 lbs.

- Double entrance holes (top)
- Factory bussed 400 Amp Mains
- 200 Amp, 600 VOLT per position
- 2 - 6 position horizontal
- 4 Jaw meter sockets
- CSA weatherproof enclosure 3
- Approved conductor range:
Line 1 - No. 2 - 600 MCM CU/AL
or Two - 1/0 - 250 MCM CU/AL
Load No. 6 - 250 MCM CU/AL

- For overhead order "HD" Series hub separate
- Add suffix "H" for right hand entry, contact sales office for cost
- Approved for overhead installations only
- Use SXX503 for 5th jaw at 9 O'clock
- Use SXC022 for water heater lug kit

KNOCKOUT CODE	CONDUIT SIZE
G	1 ¹ / ₄ ", 1 ¹ / ₂ ", 2", 2 ¹ / ₂ "
S	3", 3 ¹ / ₂ ", 4"
AA	1 ¹ / ₂ "

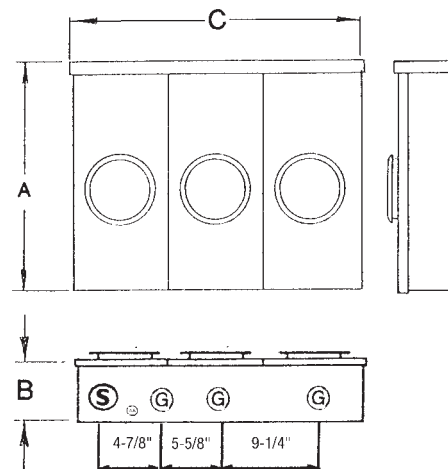

HC40 Series



200 AMP - MULTI POSITION 400 Amp Mains c/w Blank Wiring Comp.

CATALOGUE #	DESCRIPTION	METER POSITIONS	ENCLOSURE SIZE A X B X C	WEIGHT
HC42R	2 gang, c/w blank compartment on left side	2	22 ³ / ₄ " x 6 ¹ / ₄ " x 28"	48 lbs.
HC43R	3 gang, c/w blank compartment on left side	3	22 ³ / ₄ " x 6 ¹ / ₄ " x 37 ³ / ₈ "	65 lbs.
HC44R	4 gang, c/w blank compartment on left side	4	22 ³ / ₄ " x 6 ¹ / ₄ " x 46"	83 lbs.
HC45R	5 gang, c/w blank compartment on left side	5	22 ³ / ₄ " x 6 ¹ / ₄ " x 56 ¹ / ₈ "	103 lbs.
HC46R	6 gang, c/w blank compartment on left side	6	22 ³ / ₄ " x 6 ¹ / ₄ " x 65 ¹ / ₂ "	121 lbs.

- Double entrance holes (top)
- Factory Bussed 400 Amp Mains
- 200 Amp, 600 VOLT per position
- 2 - 6 position horizontal
- 4 Jaw meter sockets
- CSA weatherproof enclosure 3
- Approved conductor range:
Line 1 No. 2 - 600 MCM CU/AL
or two - 1/0 -250 MCM CU/AL
Load No. 6 - 250 MCM CU/AL
- May be field converted for use with single stud 500 mcm

- For overhead order "HD" series hub separate
- Add suffix "H" for right hand entry, contact office for cost
- Approved for overhead & underground installations
- Use SXX503 for 5th jaw at 9 O'clock
- Use SXC022 for water heater lug kit

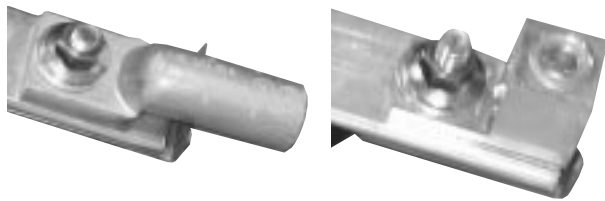

KNOCKOUT CODE	CONDUIT SIZE
G	1 ¹ / ₄ ", 1 ¹ / ₂ ", 2", 2 ¹ / ₂ "
S	3", 3 ¹ / ₂ ", 4"
AA	1 ¹ / ₂ "

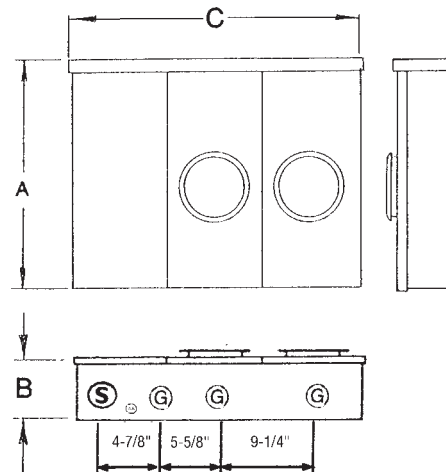
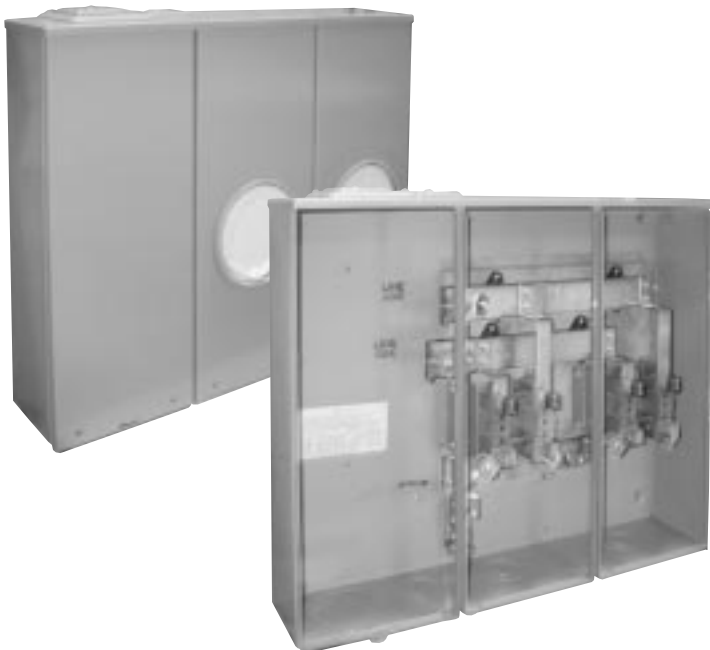

MSC Series



METER
SOCKETS

200 AMP - MULTI POSITION STUD TYPE 400 Amp Mains c/w Blank Wiring Comp.

CATALOGUE #	DESCRIPTION	METER POSITIONS	ENCLOSURE SIZE A X B X C	WEIGHT
MSC42TW	2 gang, c/w 1/2" compression studs	2	22 ³ / ₄ " x 6 ¹ / ₄ " x 28"	48 lbs.
MSC43TW	3 gang, c/w 1/2" compression studs	3	22 ³ / ₄ " x 6 ¹ / ₄ " x 37 ³ / ₈ "	65 lbs.
MSC44TW	4 gang, c/w 1/2" compression studs	4	22 ³ / ₄ " x 6 ¹ / ₄ " x 46 ³ / ₄ "	83 lbs.
MSC45TW	5 gang, c/w 1/2" compression studs	5	22 ³ / ₄ " x 6 ¹ / ₄ " x 56 ¹ / ₈ "	103 lbs.
MSC46TW	6 gang, c/w 1/2" compression studs	6	22 ³ / ₄ " x 6 ¹ / ₄ " x 65 ¹ / ₂ "	121 lbs.

* Also available with two (2) blank compartments (see MSC800 Series)

- Factory Bussed 400 Amp Mains
- 200 Amp, 600 VOLT per position
- 2 - 6 position horizontal
- 4 Jaw meter sockets
- CSA weatherproof enclosure 3
- Approved conductor range:
Line - studs (1/2" per phase) provided for compression type wire connectors
Load - #6 - 250 MCM CU/AL
- Underground only

- Use SXX503 for 5th jaw at 9 O'clock
- Use SXC022 for water heater lug kit

KNOCKOUT CODE	CONDUIT SIZE
G	1 ¹ / ₄ ", 1 ¹ / ₂ ", 2", 2 ¹ / ₂ "
S	3", 3 ¹ / ₂ ", 4"
AA	1/2"

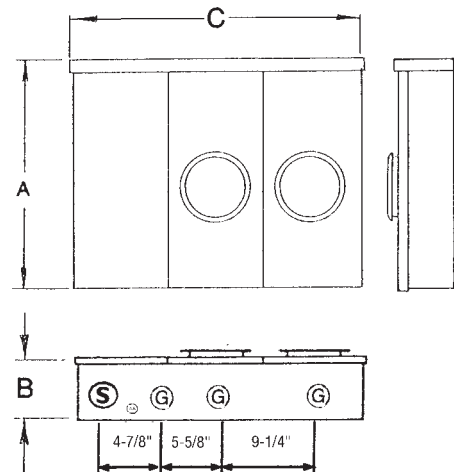
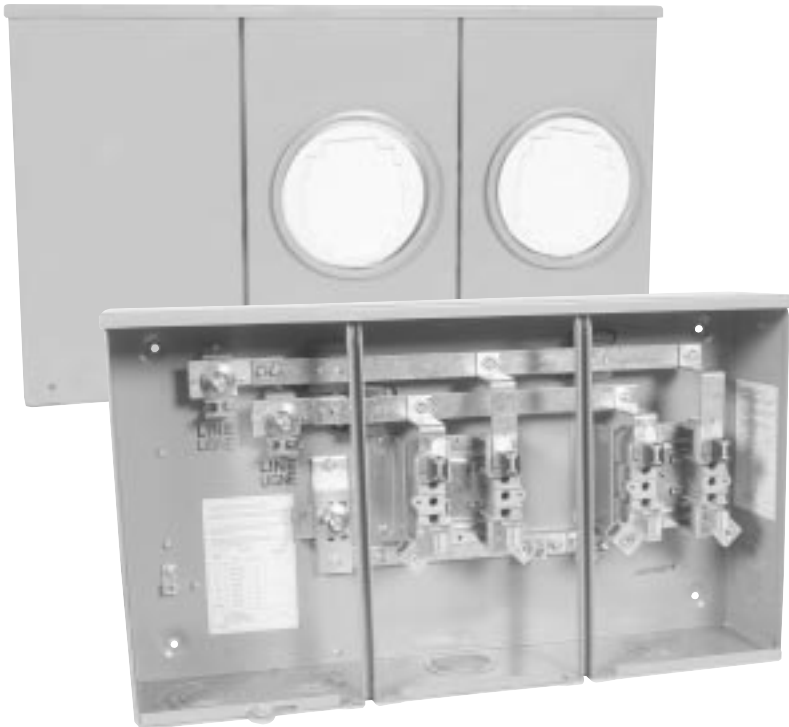

Brampton Hydro approved units available with 4 1/2" studs per phase. Add suffix -2 to above numbers.

MSC Series



200 AMP - MULTI POSITION STUD TYPE 400 Amp Mains c/w Blank Wiring Comp.

CATALOGUE #	DESCRIPTION	METER POSITIONS	ENCLOSURE SIZE A X B X C	WEIGHT
MSC820TW	2 gang, c/w 1/2" compression studs	2	22 ³ / ₄ " x 6 ¹ / ₄ " x 37 ³ / ₈ "	53 lbs.
MSC830TW	3 gang, c/w 1/2" compression studs	3	22 ³ / ₄ " x 6 ¹ / ₄ " x 46 ³ / ₄ "	70 lbs.
MSC840TW	4 gang, c/w 1/2" compression studs	4	22 ³ / ₄ " x 6 ¹ / ₄ " x 56 ¹ / ₈ "	88 lbs.
MSC850TW	5 gang, c/w 1/2" compression studs	5	22 ³ / ₄ " x 6 ¹ / ₄ " x 65 ¹ / ₂ "	108 lbs.
MSC860TW	6 gang, c/w 1/2" compression studs	6	22 ³ / ₄ " x 6 ¹ / ₄ " x 74 ¹ / ₄ "	126 lbs.

* Also available with one (1) blank compartment (see MSC42TW Series)

- Factory Bussed 400 Amp Mains
- 200 Amp, 600 VOLT per position
- 2 - 6 position horizontal
- 4 Jaw meter sockets
- CSA weatherproof enclosure 3
- Approved conductor range:
Line - studs (two 1/2" per phase) provided for compression type wire connectors
Load - #6 - 250 MCM CU/AL
- Underground only
- Also approved in Ottawa area

Use SXX503 for 5th jaw at 9 O'clock
Use SXC022 for water heater lug kit

KNOCKOUT CODE	CONDUIT SIZE
G	1 ¹ / ₄ ", 1 ¹ / ₂ ", 2", 2 ¹ / ₂ "
S	3", 3 ¹ / ₂ ", 4"
AA	1/2"

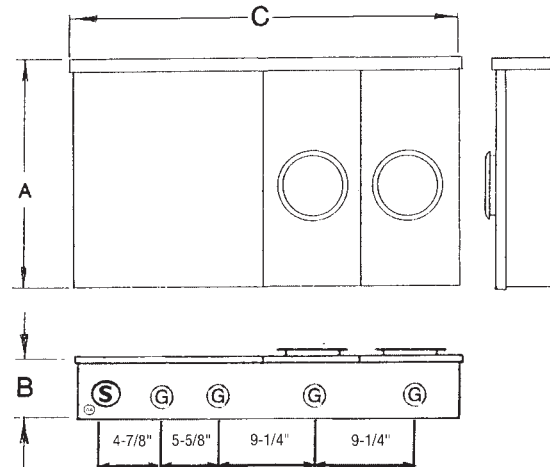

STVC Series



200 AMP - DOUBLE METERING Demand & Watt Hour Meter

CATALOGUE #	DESCRIPTION	WEIGHT
STVC501PW	5 Jaw - 6 O'clock	36 lbs.
STVC703PW	7 Jaw - c/w insulated neutral	40 lbs.

- Supplied factory bussed - series connection
- CSA weatherproof enclosure 3
- 200 Amps - 600 VOLTS
- Conductor range #6 - 250 MCM CU/AL
- This is not a multi-position meter socket

- Order "HD" series hubs separate



KNOCKOUT CODE	CONDUIT SIZE
M	2", 2 1/2", 3"
AA	1/2"

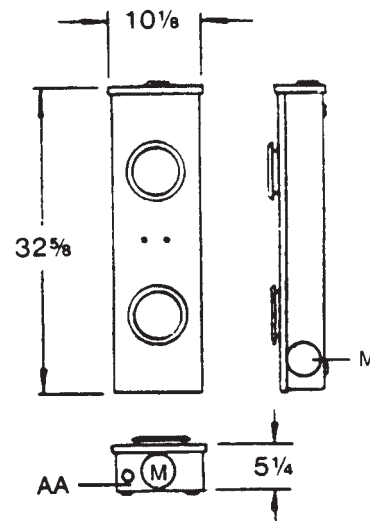

CT4 Series



400 AMP METER SOCKET 120/240 VOLT, Single Phase

METER
SOCKETS

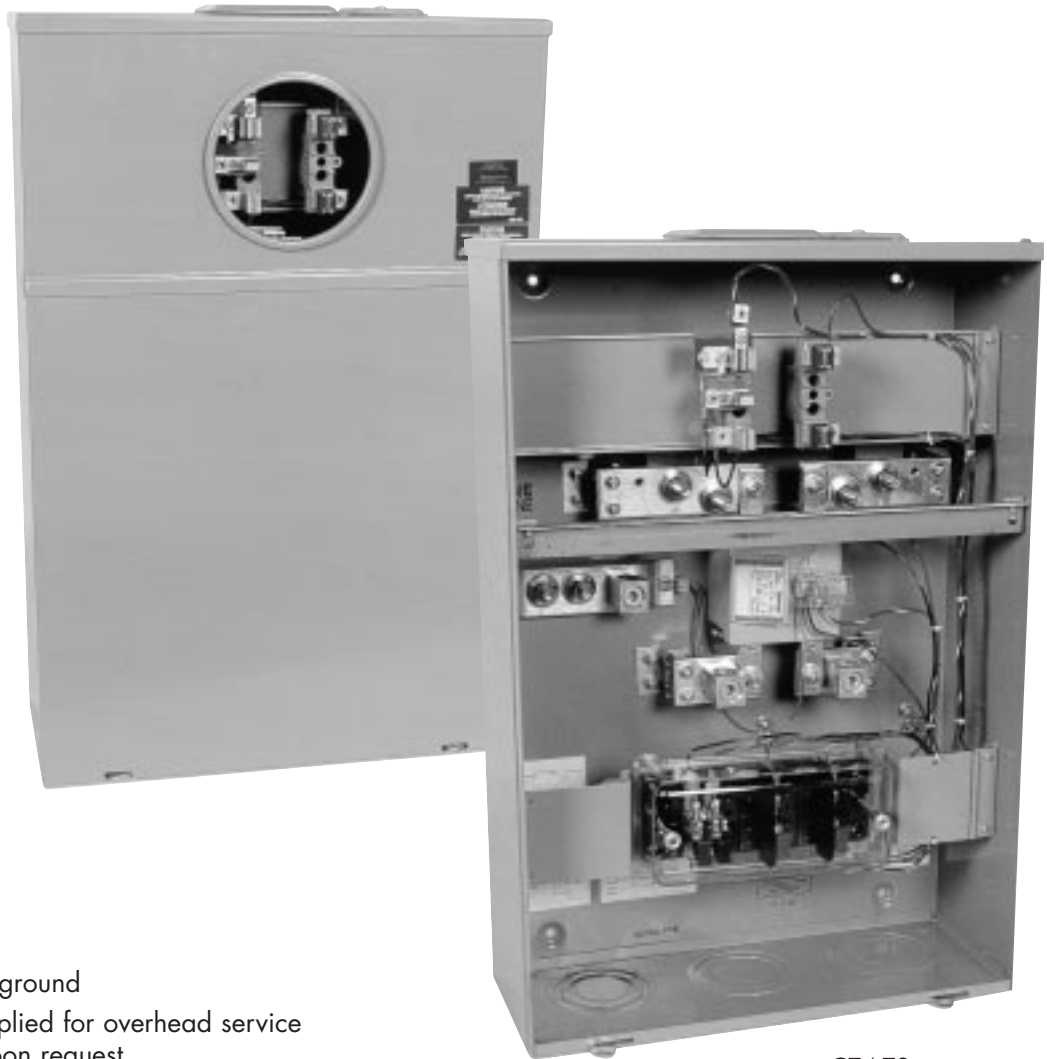

CT4-TS

- Overhead/Underground
- Tunnel lug kit supplied for overhead service
LK250, LK500 upon request
- Line side - double $\frac{1}{2}$ " studs to accommodate
compression lugs for underground service
(1 x 500 MCM or 2 x 250 MCM)
Load side - one #4 - 600 MCM
or two $\frac{1}{0}$ - 250 MCM tunnel type connectors
Neutral - $\frac{1}{2}$ " studs to accept two 500 MCM
compression type lugs
- lugs, one #4 - 600 MCM or
two $\frac{1}{0}$ - 250 MCM
- Dimensions, 30" x 20" x 8" or 36" x 20" x 8"
Weight, 75 lbs. or 80 lbs.
Ko's 3" - $3\frac{1}{2}$ ", 4"
- CSA approved

CT4 Series



400 AMP METER SOCKET 120/240 VOLT, Single Phase

CATALOGUE #	ENCL. SIZE	JAWS	BY-PASS	CT RATIO	TEST SWITCH	WIRE	REGION
CT4	36"	5	Yes	No	No	Yes	Ontario
CT4-2	36"	5	Yes	200:5	No	Yes	Ontario
CT4-3	36"	5	Yes	300:5	No	Yes	Ontario
CT4-4	36"	5	Yes	400:5	No	Yes	Ontario
CT4-TS	30"	4	No	400:5	Yes	Yes	New Brunswick
CT4-TS-OT	30"	4	Yes	No	Yes	No	Ottawa
CT4-TS5	36"	5	Yes	400:5	Yes	Yes	Ontario
CT4-TSB	30"	5	Yes	400:5	Yes	Yes	Ontario
CT4-TSB2/CT4-2TS	30"	5	Yes	200:5	Yes	Yes	Ontario
CT4-TSB3	30"	5	Yes	300:5	Yes	Yes	Ontario
CT4-2W	36"	4	By-Pass	200:5	No	Yes	Waterloo
CT4-BC	36"	4	No	No	No	No	British Columbia
CT4-NS	30"	4	No	No	No	Yes	Nova Scotia
CT4-S	36"	5	Yes	No	No	Yes	Saskatch./Ont.
	Accessories						
CT4-PMK	Pole Bracket for 30" enclosure						
CT4-PMK36	Pole Bracket for 36" enclosure						
	Conversion Kits supplied on request						
LK250	Twin 250 MCM lug kit						
LK500	Single 500 MCM lug kit						

- Overhead/Underground
- Hub plate supplied for underground service
- Lug kit supplied separately for overhead service
- Line side - double 1/2" studs to accommodate compression lugs for underground service (1 x 500 MCM or 2 x 250 MCM)
Load side - one #4 - 600 MCM
or two 1/0 - 250 MCM tunnel type connectors
Neutral - 1/2" studs to accept one 500 MCM compression type lugs
- lugs, one #4 - 600 MCM or
two 1/0 - 250 MCM
- CT, three wire current transformer provides low current for service metering proportional to higher current draw approved by CCA Canada
- CSA approved

Panel Mounting Socket

TAYLOR FUSE PULLOUTS



	RING STYLE SOCKET MOUNTED ON DIE CAST RING		PLATE STYLE SOCKET MOUNTED ON 10" X 10" 16 GA STEEL PLATE COVER	
DESCRIPTION	CAT. #	COLUMN DESCRIPTION	CAT. #	COLUMN DESCRIPTION
100 Amp - 600 Volt #6 - 1/0 AWG CU/AL	R4-1	4 Jaw	P4-1	4 Jaw
	R5-1	5 Jaw	P5-1	5 Jaw
	R7-1	6 O'clock 7 Jaw	P7-1	6 O'clock 7 Jaw
200 Amp - 600 VOLT #6 - 250 MCM CU/AL	R4-2	4 Jaw	P4-2	4 Jaw
	R5-2	5 Jaw	P5-2	5 Jaw
	R7-2	6 O'clock 7 Jaw	P7-2	6 O'clock 7 Jaw
Transformer rated units 20 Amps - 600 VOLTS #14 - #8 CU	R8	8 Jaw	P8	8 Jaw
	R13	13 Jaw	P13	13 Jaw
	R139	13 Jaw c/w by-pass	P139	13 Jaw c/w by-pass

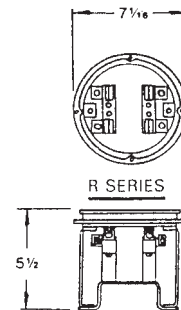

WEIGHT

100 Amp - 8 lbs.
200 Amp - 10 lbs.

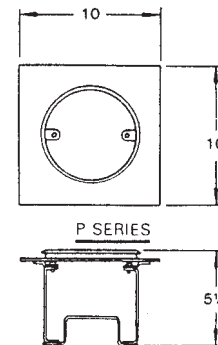

Retrofits Taylor

TAYLOR FUSE PULLOUTS	CAT. #	POLES	AMPS	DESCRIPTION
ADDING/REPLACEMENT MODULES NHP Fuse Panel Series and HP (Combination) Service Entrance Panel Series 	215	2-SP	30	Module
130A	130A	1-2P 1-2P	30 30	Base Pullout
160	160	1-2P 1-2P	60 60	Base Pullout

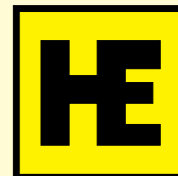

Interchangeable Hubs for 2 1/2" Hub Opening

CATALOGUE #	DESCRIPTION	WEIGHT	
SXC100	1"	40 lbs./100	
SXC125	1 1/4"	40 lbs./100	
SXC150	1 1/2"	40 lbs./100	
SXC200	2"	40 lbs./100	
SXC250	2 1/2"	40 lbs./100	

Mast Coupler

CATALOGUE #	DESCRIPTION	WEIGHT	
MC200	One size c/w screw A great time and money saver in overhead installation - replaces bottom reducers and SXC series meter socket hubs Will accommodate 1 1/4" and 2"	35 lbs./100	
MC200S	same as above		

Interchangeable Hubs for 4 1/4" Hub Opening

CATALOGUE #	DESCRIPTION	WEIGHT	
HD200	2" H40, STC, SFVC, STVC, HC40	8 lbs./10	
HD250	2 1/2" H40, STC, SFVC, STVC, HC40	8 lbs./10	
HD300	3" H40, STC, SFVC, STVC, HC40	8 lbs./10	
HD350	3 1/2" H40, STC, SFVC, STVC, HC40	8 lbs./10	
HD400	4" H40, STC, SFVC, STVC, HC40	8 lbs./10	

Replacement Hub Plate - Closing

CATALOGUE #	DESCRIPTION	WEIGHT	
SXC000	Small hub opening, 2 1/2"	2 lbs./10	
HD000	Large hub opening, 4 1/4"	6 lbs./10	
HD2025	Adapter plate reduces 4' opening to hub size	8 lbs./10	



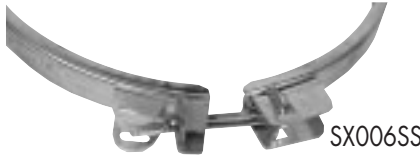

SEALING RINGS / COVERS

Meter Socket Sealing Rings

CATALOGUE #	DESCRIPTION	WEIGHT	
SX001M	Slip Lock Type	15 lbs./100	
SX002M	Latch Type or Buckle Type (Meter Sealing Ring)	17 lbs./100	
SX006M	Adjustable Screw Type - Aluminum	17 lbs./100	
SX006SS	Stainless Steel Screw Type Tamperproof Acrylic (Peerless)	25 lbs./100	
SX008M		25 lbs./100	

Meter Opening Cover Plates

CATALOGUE #	DESCRIPTION	WEIGHT	
SX087MD	Hard Plastic	12 lbs./100	
SX087MC	Clear Lexan	12 lbs./100	
SX087CB	Clear Bladed Lexan	13 lbs./100	
SX025P	Plastic (temporary) - Throw Away	1 lb./100	
SX087S	Steel	1 lb.	
SX087SMC-5	Meter Protector 5" Depth – Entire Front Lifts	3 lbs.	
SX087SMC-9	Meter Protector 9" Depth – Entire Front Lifts	5 lbs.	
SX087PG	Meter Puller (Polycarbonate Plastic)	3 lbs.	
SX087SMC-1	Glass Meter Protector 5" Depth Screwless installation	3 lbs.	



Meter Seals

CATALOGUE #	DESCRIPTION	WEIGHT	
FA100G	Padlock Galvanized c/w Stainless Steel Wire (STD PAC 200)	15 lbs./m	
FA400P	Plastic Padlock c/w Stainless Steel Wire (STD PAC 1000) - Embossing & various colours available	14 lbs./m	
FA300P	All Plastic Padlock - Orange (STD PAC 1000) - Embossing & various colours available	1 lb./m	
FA200M	Lead Seal c/w 6" Wire (STD PAC 250)	10 lbs./m	
FA209M	Lead Seal c/w 9" Wire (STD PAC 250)	11 lbs./m	
FA71A-5	Sealing Press (Crimpers) c/w Built-in Wire Cutters (Die Engraving Available) For Lead Seals	1 lb. Each	

Socket Meter Disconnect Sleeve

CATALOGUE #	DESCRIPTION	WEIGHT	
AD500	Clear Mylar - 144 pieces per package	1 lb./m Sold in Pkg. Of 144 Only	
AD100	Red Vinyl - 144 pieces per package	1 lb./m Sold in Pkg. Of 144 Only	

Jumper Bars / Cover

CATALOGUE #	DESCRIPTION	WEIGHT	
JB2	Insulated, 200 Amp Max. Jumper Bars	5 lbs./100	
JC4B	Jumper Covers, 4 Jaw c/w Handle	1 lb. each	
JC6B	Jumper Covers, 7 Jaw c/w Handle	1 lb. each	

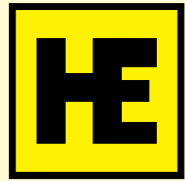

5TH JAW KITS

Insulated Neutrals and 5th Jaw Assemblies

CATALOGUE #	DESCRIPTION	
INK 100	Insulated Neutral - 100 Amp, 14 - 1/0 SE400 Series SFC 700	
INK 105 INK105Y	5TH Jaw in 6 O'clock, 14 - 1/0 SE400	
INK 200	Insulated Neutral, 200 Amp, 6-250 MCM EK400 Series STC700 Series SLC400 Series	
INK 501	5th Jaw in 6 O'clock, 6-250 MCM Used on all 200 Amp Sockets	
SXX 503 SXX503BC SXX503T	5th Jaw in 9 O'clock, 14 - 1/0 Used on all 100 Amp and 200 Amp Sockets 5th Jaw in 9 O'clock BC only, 14 - 1/0 5th Jaw - Toronto Hydro approved, 14 - 1/0	

Insulated Neutral Replacement Block

CATALOGUE #	DESCRIPTION	WEIGHT	
INK100 INK200	100 Amp Insulated Neutral 200 Amp Insulated Neutral	2 lbs./10 6 lbs./10	

Fifth Jaw Assemblies

CATALOGUE #	DESCRIPTION	WEIGHT	
SXX503	For All 100 Amp & 200 Amp EK, SLC, E, SE, SH, SD - 9 O'clock	1 lb./10	
INK105	For SE - 6 O'clock position - 100 Amp - Old Style	2 lbs./10	
INK105Y	For all SE - 6 O'clock position - To fit all new style with yellow jaw shrouds Manufactured after 08/01/03		
INK501	For EK c/w Neutral and 5th Jaw - 6 O'clock position - 200 Amp.	6 lbs./10	

Conversion Kits

CATALOGUE #	DESCRIPTION	WEIGHT	
SXC022 SXCONY SS002	Waterheater Lug Kit, 14 - 6 (MSC + H Series) North York Dead End Ass'y., 14 - 6 SLC, MSC, SE Safety Shrouds (100 Amp and 200 Amp Jaws)	5 lbs./100 5 lbs./100 1 lb./1000	

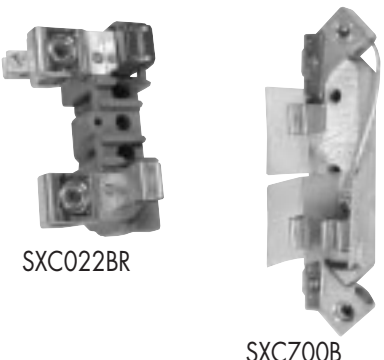
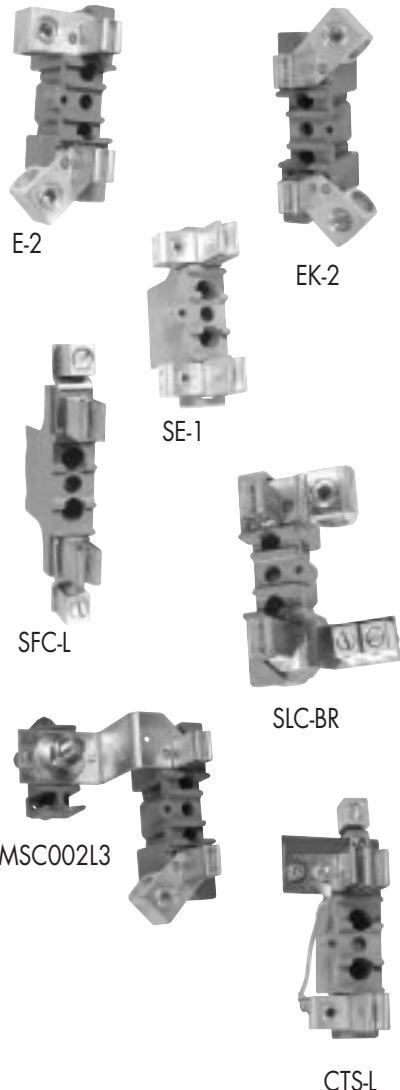

Replacement Block Assemblies

CATALOGUE #	DESCRIPTION		
MSC002L	MSC Series Porcelain Only	Left	 <p>SXC022BR</p> <p>SXC700B</p>
MSC002R	MSC Series Porcelain Only	Right	
SXC002B	SLC & STC Porcelain Only	Standard	
SXC022BL	SLC with w/h lug SLC 420	Left	
SXC022BR	SLC with w/h lug SLC 420	Right	
SXC700B	STC Centre Phase		
EK-2	EK Series		 <p>E-2</p> <p>EK-2</p> <p>SE-1</p> <p>SFC-L</p> <p>SLC-BR</p> <p>MSC002L3</p> <p>CTS-L</p>
E-2	E400RO Series Straight Lug lineside		
SE-1	SE & SH - JA	Standard	
SE-L	SE with w/h lug SE420RW	Left	
SE-R	SE with w/h lug SE 420 RW	Right	
SFC-L	SFC Centre Phase	Left	
SFC-R	SFC Centre Phase	Right	
SFC-E	SFC End Block	Left & Right	
SD-L	SD Series	Left	
SD-R	SD Series	Right	
HC-L	HC & H Series, Old porcelain style	Left	
HC-R	HC & H Series, Old porcelain style	Right	
SLC-BL	SLC 402, Subfeed style	Left	
SLC-BR	SLC 402, Subfeed style	Right	
MSC002L3	Plastic MSC400TW	Left	
MSC002R3	Plastic MSC400TW	Right	
H22BL	H22 Series plastic	Left	
H22BR	H22 Series plastic	Right	
HC-LP	H40 Series plastic	Left	
HC-RP	H40 Series plastic	Right	
SLC-P	SLC Series plastic	Left & Right	
CTS-L	CTS 409 c/w by pass	Left	

Typical Wiring Diagrams



CATALOGUE #	REFERENCE METER SOCKETS	CATALOGUE #	REFERENCE METER SOCKETS
SH400 SE400 SLC400 MSC400 E400		CTS409	
SE500 SLC500		CTS800	
SFC700 STC700		CTS130 CTS139	
SE503 SE501 SLC503 SLC501			

Meter Sockets

CROSS REFERENCE LIST



HYDEL MURRAY JENSEN	CUTLER HAMMER COMMANDER	THOMAS & BETTS MICRO	HYDEL MURRAY JENSEN	CUTLER HAMMER COMMANDER	THOMAS & BETTS MICRO
EK400P	J2	BQ2-V	STC703PK	P27-1N2	PL27-INV
EK400L	J2-2	BQ2-2V	STC700RK	—	PL27-TCV
EK400D		BQ2-22V	SFVC703PW	2VP17	VT1-7V
EK400T	JU2	BQ2-TV	SFVC503PW	2vk1n	VT1-6V
EK400TO	LU2	BS2-TVO	STVC703PW	2VP27	VT2-7V
EK400R	JM2		STVC501PW	2VK2	VT2-6V
EK400ROBC	LMB3	BS2-TCVBC	CTS130PW	TSU-13	CT113
EK400RO	LM2	BS2-TCV	CTS400PW	TSU-4	CT104
EK400DP	J22	BQ2-22VNH	CTS409PW	TCC4-0	CL4-V
MSC400TW	CLX	MO2-V	CTS405PW	TSU-5	—
MSC420TW	CLX-SF	SC-2WV	CTS459PW	TCC5-0	CL5-V
SLC420RW	LM2-W2		CTS500PW	TSU-5	CT105
SLC400RW		BS2L-TCV	CTS800PW	TSU-8	CTS108
SLC400RWBC		N/A	CT4	TCC5	JS4A
SLC402RW	LM2-SF	BS2M-V	CT4-TS	TCC5-4-TS	JS4B
SE400JW	K1N1-1/4	BE1-11/4V	JA000PW	RC1N	CO1
SE400PW	K1-N	BE1-V	JA402PSD	RC2-2200	CO2-200
SE400TW	KU1N	BE1-TV	JA400RW	RC1-2200	
SE400RW	K1M-N	BE1-TCV	SX008M	SR4	S102WD
SE420RW	KIMW2-N	BE1-TCVW	SX006M	SR3	SM002A
SE400BP		BE11-VCM	SX087MD	1MMACP	BS087
SE400BW		BE11-1-1/4V	MC200		MH200
SH400JW	S1-N1-1/4	BA-3-1-1/4V	SXC000	MS1078	MS051
SH400PW	S1-N	BA3-TCV	SXC100	H1	MH10X
SH400BW	S12-N1-1/4	BA-331-1/4V	SXC125	H1-1/4	MH12X
SH400BP	S12-N	BA33-V	SXC150	H1-1/2	MH15
SH400KO	S11-N	BA4-V	SXC200	H2	MH200
SH400TW	—	BA3-TV	SXC250	H2 1/2	MH25
H22R	2K2	BD2-V	HD300	HA3	MH30
H23R	3K2	BD3-V	HD350	HA 31/2	MH35
H24R	4K2	BD4-V	HD400	—	MH40
HC42R	2K4	BS42-V	JB-2	JB2	CM-BS100
HC43R	3K4	BS43-V	INK100	1N1	IN1000 BA, BE, PL
HC44R	4K4	BS44-V	INK200	1N2	IN2000 BS, PL
HC45R	5K4	BS45-V	INK105 Y	FJ1-6	B106 CM-B106
HC46R	6K4	BS46-V	SXCONY	NYK30	KNY
MSC820TW	2KU4CLX	BSC42-V	SXK503	FJ1-2	Z105
MSC830TW	3KU4CLX	BSC43-V	SXK503BC		
MSC840TW	4KU4CLX	BSC44-V	MCC220TW	2KNU1CLX	BEC2-V
MSC850TW	5KU4CLX	BSC45-V	MCC320TW	3KNU1CLX	BEC3-V
MSC860TW	6KU4CLX	BSC46-V	MCC420TW	4KNU1CLX	BEC4-V
SDC220PW	2KN1	BEC2-VA	MCC520TW	5KNU1CLX	BEC5-V
SDC320PW	3KN1	BEC3-VA	MCC620TW	6KNU1CLX	BEC6-V
SDC420PW	4KN1	BEC4-VA	MSC22R	2KU2CLX	BDC2-V
SD220PW	N/A	BE-2V	MSC23R	3KU2CLX	BDC3-V
SD320PW	N/A	BE-3V	MSC24R	4KU2CLX	BDC4-V
SD420PW	N/A	BE-4V			
SD520PW	N/A	BE-5V			
SD620PW	N/A	BE-6V			
SFC700PW	P17-0	PL17-V			
SFC703PW	P17-0-1N1	PL17-TCVIN			
STC700PK	P27	PL27-V			

*Add suffix "NS" to all meter sockets used in New Brunswick.

Custom Enclosures



ONTARIO HYDRO / SCARBOROUGH ENCLOSURES

**Ontario Hydro
Meter Cabinet**



CATALOGUE #	WEIGHT	ENCLOSURE SIZE H X W X D
74820585	44 lbs.	24" x 16" x 10"

Milk Box
*Used to enclose
Meter Socket
recessed in wall*



CATALOGUE #	WEIGHT	ENCLOSURE SIZE H X W X D
ST301812SC Cover Size	60 lbs.	30" x 18" x 12" 33 ¹ / ₄ " x 21 ¹ / ₈ "
ST301412SC Cover Size	55 lbs.	30" x 14" x 12" 31" x 15"

Mast and Accesories



MAST AND ACCESSORIES

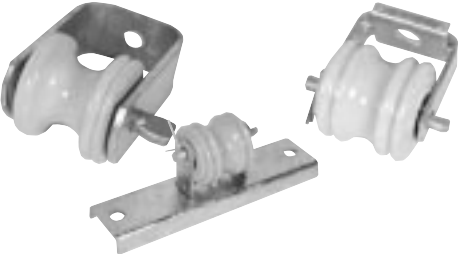
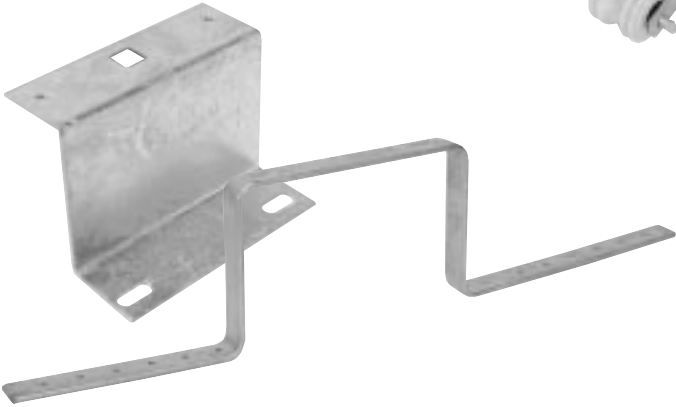
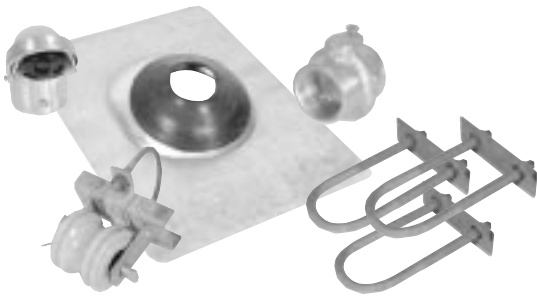
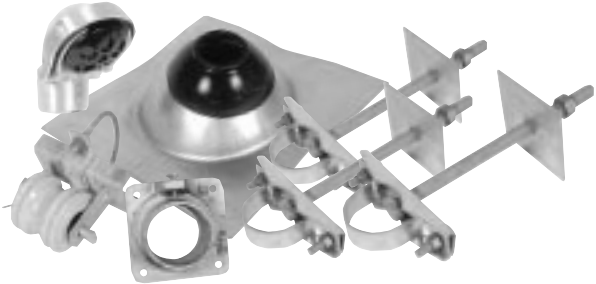

MAST AND ACCESSORIES

2 1/2" Bungalow Service



ENTRANCE STACKS & ACCESSORIES

MAST AND ACCESSORIES

CATALOGUE #	DESCRIPTION
2521 2521-1-1/2 2521-2	100 Amp entrance cap - completely weatherproof As 2521 but with insert for 200 Amp or 150 Amp service 2" Cap for 200 Amp service
2508 2509 2510 2512	Service Entrance Masts - 2 1/2" O.D. 8 Ft. Service Entrance Mast 9 Ft. Service Entrance Mast 10 Ft. Service Entrance Mast 12 Ft. Service Entrance Mast
25C 2515 2517-U 2518-U 417U 2513	Service mast ground clamp Guy attachment with eye bolt 200 Amp heavy duty triplex cable rack 100 Amp light duty triplex cable rack Oversize Cable Rack for 3" Pipe Guy attachment with hook
2506B 2506 2506NB 2506N-2 2526NB 2526N 2506-3	Weatherproof Roof Flange c/w Steel Collar (No longer available - Substitute 2526NB) Complete with undereave flashing All neoprene roof flange - one piece construction Neoprene Collar only Steel roof flange with neoprene collar - 2 piece construction As 2526NB but c/w undereave flashing Undereave flashing only
2014-U 2504 2505 2504-6 2504-12 2504-LB	Clamp - 1/2" diameter Clamp assembly for mounting stack on brick, concrete block, etc. Complete with 4" x 4" galvanized washer and 5/8" x 10" bolt As above with 5/8" x 4 1/2" bolt std. thread for wood frame As above with 5/8" x 6" bolt std. thread As above with 5/8" x 12" bolt As above less thru bolt & washer
2507-5/8 506-5/8 506 5061 2516 2516-L	Meter spacer c/w pipe strap. c/w 5/8" x 4 1/2" Carrige bolt and 4" x 4" Washer As above less stack clamp Meter spacer only (Z plate) Meter spacer (top hat) Stack clamp for surface mounting Same as above but c/w 3 lag screws 3/8" x 3"
2501 2525 2550 2502 2502MS	Add "M" to catalogue # (eg. 2501-M) for male thread. 1" Bottom Reducer 1 1/4" Bottom Reducer 1 1/2" Bottom Reducer 2" Bottom Reducer 2" Reducer Offset (Special)

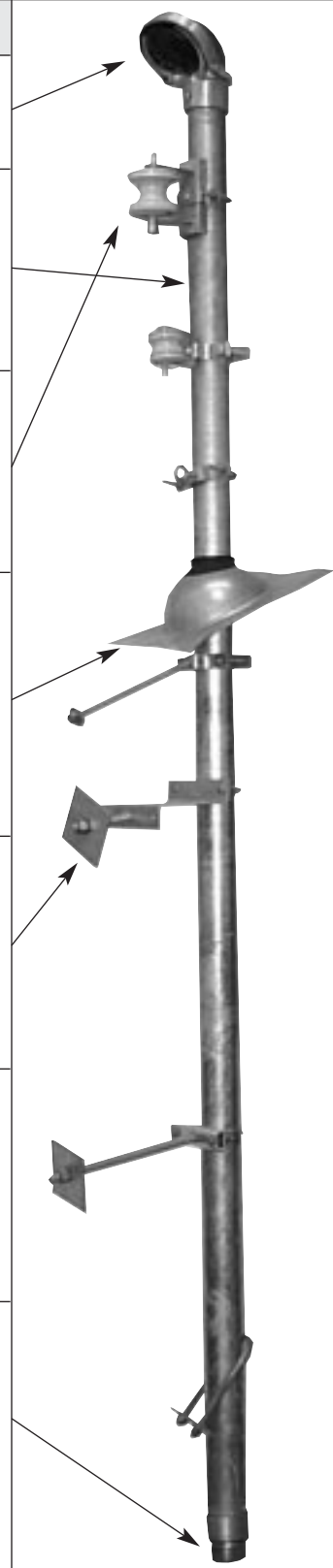

2 1/2" Bungalow Service

ENTRANCE STACKS & ACCESSORIES

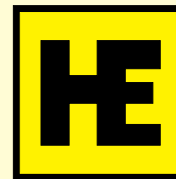

MAST AND ACCESSORIES

Service Entrance Top Cap

CATALOGUE #	DESCRIPTION	
2521 2521-2	1 1/4" entrance cap, 100 Amp, completely weatherproof. Extra large (-2) cap for 200 Amp service	

Triplex Cable Rack

CATALOGUE #	DESCRIPTION	
2517-U 2518-U 417-U	200 Amp spool rack - heavy duty, c/w insulator 100 Amp spool rack - light duty, c/w insulator 200 Plus - spool rack - oversize 3" to 4" pipe	
2513 2515 25C	Drop wire hook bracket Guy attachment with eye bolt Mast ground clamp #8 - 1/0	

Weatherproof Roof Flange - Adjustable to Roof Pitch

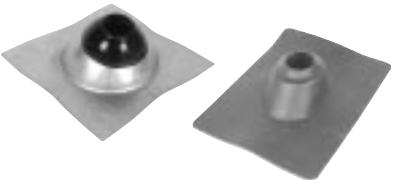
CATALOGUE #	DESCRIPTION	
2506 2506NB 2526NB 2506N 2506-3 2506N2	Complete with undereave flashing & rubber collar All neoprene roof flange - One piece construction Steel roof flange with neoprene collar - two peice const. As 2526NB but c/w undereave flashing Undereave flashing only Neoprene collar only	

Stack Clamp for Surface Mounting

CATALOGUE #	DESCRIPTION	
2516 2516-L 2516-L4	Stack clamp for surface mounting Same as above but complete with 2 lag screws 3/8" x 3" As above c/w 3/8" x 4" Lags	

Thru Bolt Stack Clamp

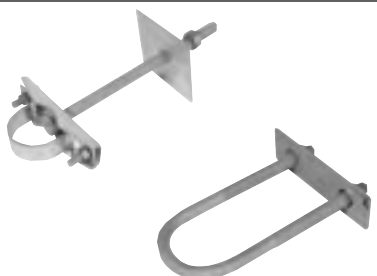
CATALOGUE #	DESCRIPTION	
2504 2504-6 2504-12 2504-LB 2505 2014U	Clamp assembly for mounting stack on brick, concrete block, etc. Complete with 4" x 4" galvanized washer and 5/8" 10 bolt with 8" of thread As above but with 6" bolt As above but with 12" bolt As above less thru bolt and washer As above but with 5/8" x 4 1/2" bolt, std. thread for wood frame wall U-bolt rafter clamp 1/2"	

2 1/2" Bungalow Service

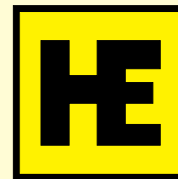

ENTRANCE STACKS & ACCESSORIES

MAST AND ACCESSORIES

Brick Spacer Clamp

CATALOGUE #	DESCRIPTION	
2507-5/8	Permits installation of complete service entrance stack before building is bricked. May be used to hold any size conduit by changing pipe strap. Complete with 5/8" x 4 1/2" galvanized bolt and 4" x 4" washer.	
506-5/8	Same as above less stack clamp. Simplifies mounting meter socket on walls before bricking.	

Service Entrance Mast

CATALOGUE #	DESCRIPTION	
2508	2 1/2" O.D. high tensile steel tubing triple galvanized, rustproof	
2509		
2510		
2512		

Bottom Reducer

CATALOGUE #	DESCRIPTION	
2501M	Male and Female Combination 1" 1 1/4" 1 1/2" 2" 2" Offset (Male only) • Note: Can all be used as female by removing close nipple	
2525M		
2550M		
2502M		
2502MS		

Brick Spacers

CATALOGUE #	DESCRIPTION	
5061	Brick spacer (galv.) - top hat style Used for metric brick - 4" depth Meter socket spacer - Z plate style used for metric brick - 4" depth	
5061M		
506		
506M		

Mast Kit

ONTARIO



To make the kit contents correspond to the catalogue number, we have developed a system of 7 digits consisting of 3 figures and 4 letters as follows:

Number and letter sequence is from the top of the mast to the bottom of the mast - for instance, the reducer is the bottom item and the last digit that identifies it is (M or F).

These 7 digits completely describe the mast kits. This will make them somewhat easier to identify.

- **AMPERAGE 1 or 2 (100 or 200)**
- **PIECE ROOF FLANGE (1 or 2)**
- **CLAMPS (2 or 3)**
- **RACK H (heavy duty) or L (light duty)**
- **ROOF FLANGE N (neoprene)**
- **CLAMP T (thru bolt) or S (strap)**
- **REDUCER M (male) or F (female)**

CATALOGUE #	DESCRIPTION	
123 LNSM	100 Amp (Manitoba and Saskatchewan) Contains: 1 - 2521 Entrance cap 1 - 2518U Light duty rack 1 - 2526NB Roof flange c/w neoprene collar 2 Pc. 3 - 2516L Straps c/w lags 1 - 2525M Male/female reducer 2 Pc., 1 1/4"	
123 LNTMC	100 Amp Contains: 1 - 2521 Entrance cap 1 - 2518U Light duty spool rack 1 - 2526NB Roof flange c/w neoprene collar 3 - 2504 thru bolt (10 inch) clamp 1 - MC200 Mast coupler	
123 LNTFM	100 Amp Contains: 1 - 2521 Entrance cap 1 - 2518U Light duty spool rack 1 - 2526NB Roof flange c/w neoprene collar 3 - 2504 thru bolt (10 inch) clamp 1 - 2525M Male/female reducer, 1 1/4"	
223 HNSM	200 Amp (Manitoba and Saskatchewan) Contains: 1 - 2521-2 Entrance cap 1 - 2517U Heavy duty spool rack 1 - 2526NB Roof Flange c/w collar 2 pc. 3 - 2516L Straps c/w lags 1 - 2502M Male/female reducer 2 pc., 2"	
223 HNTFM	200Amp Contains: 1 - 2521-2 Entrance Cap 1 - 2517U Heavy duty spool rack 1 - 2526NB Roof flange c/w neoprene collar 3 - 2504 thru bolt (10 inch) clamp 1 - 2502M Male/female reducer 2"	
223 HNTWMC	200Amp (Manitoba and Saskatchewan) Contains: 1 - 2521-2 Entrance Cap 1 - 2517U Heavy duty spool rack 1 - 2526NB Roof flange c/w neoprene collar 3 - 2504 thru bolt (10 inch) clamp 1 - MC200 Mast coupler	

Mast Kit

NEW BRUNSWICK & NOVA SCOTIA



MAST AND ACCESSORIES

CATALOGUE #	DESCRIPTION	
123 NSM	100 Amp (New Brunswick & Nova Scotia) Contains: 1 - 2521 Entrance cap 1 - 2526NB Roof flange c/w neoprene collar 1 - 2525M Male reducer 2 pc. 3 - 2516L Straps with lag bolts (No Rack)	
223 NSM	200 Amp (New Brunswick & Nova Scotia) Contains: 1 - 2521-2 Entrance Cap 1 - 2526NB Roof Flange c/w neoprene collar 1 - 2502M Male reducer 3 - 2516L Straps with lag bolts (No Rack)	
123 LNSM	100 Amp (Nova Scotia) Contains: 1 - 2521 Entrance Cap 1 - 2518U Light Duty Rack 1 - 2526NB Roof flange c/w neoprene collar 1 - 2525M Male reducer 2 pc. 3 - 2516L Straps with lag bolts	
223 LNSM	200 Amp (Nova Scotia) Contains: 1 - 2521-2 Entrance Cap 1 - 2518U Light Duty Rack 1 - 2526NB Roof flange c/w neoprene collar 2 pc. 1 - 2502M Reducer (male) 3 - 2516L Straps with lag Bolts	
123 NSWMC	100 Amp (New Brunswick) Contains: 1 - 2521 Entrance Cap 1 - 2526NB Roof flange c/w neoprene collar 3 - 2516L Straps with lag bolts 1 - MC200 Mast coupler (No Rack)	
223 NSWMC	200 Amp (New Brunswick) Contains: 1 - 2521-2 Entrance Cap 1 - 2526NB Roof flange c/w neoprene collar 3 - 2516L Straps with lag bolts 1 - MC200 Mast coupler (No Rack)	
213 NSWMC	200 Amp (New Brunswick) Contains: 1 - 2521-2 Entrance cap 1 - 2506NB Roof flange - all neopr. (1pc. constr.) 3 - 2516L Straps with lag bolts 1 - MC200 Mast coupler (No Rack)	

Mast Kit

NEWFOUNDLAND



MAST AND ACCESSORIES

CATALOGUE #	DESCRIPTION	
123 LNSWMC	100 Amp (Manitoba and Saskatchewan) Contains: 1 - 2521 Entrance cap 1 - 2518U Light duty rack 1 - 2526NB Roof flange c/w neoprene collar 3 - 2516L Straps with lag bolts 1 - MC200 Mast coupler	
223 LNSWMC	200 Amp Contains: 1 - 2521-2 Entrance Cap 1 - 2518U Light duty rack 1 - 2526NB Roof flange c/w neoprene collar 3 - 2516L Straps with lag bolts 1 - MC200 Mast coupler	
113 NSWMC	200 Amp Contains: 1 - 2521 Entrance cap 1 - 2506NB Roof flange - all neopr. (1pc. constr.) 3 - 2516L Straps with lag bolts 1 - MC200 Mast coupler	

BRITISH COLUMBIA

CATALOGUE #	DESCRIPTION	
2500UR	100 Amp Contains: 1 - 2521 Entrance cap 1 - 2506NC-2 Roof flange 3 - 2014U Mast clamps 1 - 2525 Reducing adapter 1 - 2518U Light duty rack	
2500-200UR	200 Amp Contains: 1 - 2521-2 Entrance 1 - 2506NC2 Roof flange 3 - 2014U Mast clamps 1 - 2502 Reducing adapter 1 - 2518U Light duty rack	
2500MCR	100Amp. Contains: 1 - 2521 Entrance 1 - 2506NC2 Roof flange 3 - 2014U Mast clamps 1 - 2518U Light duty rack 1 - MC200 Mast coupler	
2500200MCR	200 Amp Contains: 1 - 2521-2 Entrance 1 - 2506NC2 Roof flange 3 - 2014U Mast clamps 1 - 2518U Light duty rack 1 - MC200 Mast coupler	

Mast Kit

ALBERTA



MAST AND ACCESSORIES

CATALOGUE #	DESCRIPTION	
4000N	Service Entrance Kits (1 1/4") Contains: 1 - 4001 Entrance cap 1 - 4006N Roof flange 2 - 4214 Stack clamps 1 - 4218 Triple cable rack	
2000N	Service Entrance Kits (2") Contains: 1 - 2015 Entrance cap 1 - 2006N Roof flange 2 - 4214 Stack clamps 1 - 4218 Triple cable rack 1 - 2025M Reducer to 1 1/4"	

QUEBEC

CATALOGUE #	DESCRIPTION	
200 SF	200A avec accouplement de mât. <i>(Manitoba and Saskatchewan also)</i> Les pièces suivantes sont incluses : 1 - 2521-2 capuchon d'entrée 200A 1 - 2517-U support de bobine service robuste 1 - 2526-NB ensemble pour toiture, collet néoprene 3 - 2516L-4 courroie avec 3 tire-fonds 3/8 x 4" 1 - MC200S accouplement de mât avec écrou	
200 MA	200A avec adaptateur mâle. Les pièces suivantes sont incluses : 1 - 2521-2 capuchon d'entrée 200A 1 - 2517-U support de bobine service robuste 1 - 2526-NB ensemble pour toiture, collet néoprene 3 - 2516L-4 courroie avec 3 tire-fonds 3/8 x 4" 1 - 2502MS adaptateur mâle avec écrou - 2"	
100 MA	100A avec adaptateur mâle. Les pièces suivantes sont incluses : 1 - 2521 capuchon d'entrée 100A 1 - 2518-U support de bobine service robuste 1 - 2526-NB ensemble pour toiture, collet néoprene 3 - 2516L-4 courroie avec 3 tire-fonds 3/8 x 4" 1 - 2525MS adaptateur mâle avec écrou - 1-1/4"	
100 SF	100A avec accouplement de mât. Les pièces suivantes sont incluses : 1 - 2521 capuchon d'entrée 100A 1 - 2518-U support de bobine service robuste 1 - 2526-NB ensemble pour toiture, collet néoprene 3 - 2516L-4 courroie avec 3 tire-fonds 3/8 x 4" 1 - MC200S accouplement de mât avec écrou.	

Wall Racks

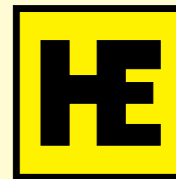

MAST AND ACCESSORIES

CATALOGUE #	DESCRIPTION	
217-U	Flat Mount Clevis 200Amp. Heavy Duty Dead End Cable Anchor	
222-R	Flat Mount Clevis 100 Amp Light Duty Dead End Cable Anchor c/w $\frac{5}{8}$ Mounting Holes	
117	Flat Mount 200 Amp Heavy Duty Triplex Cable Rack	
122	Flat Mount 100 Amp Light Duty Triplex Cable Rack	
214 CLB	Swivel Clevis (less insulator) Mainly used in Atlantic, Canada	
214 S	Swivel Clevis c/w 1606 WSP Spool Insulator $\frac{11}{16}$ Mounting Hole	

Mast Guy Kits

CATALOGUE #	DESCRIPTION	WEIGHT	
25516 GK	ONTARIO Mast Guying Kit Contents in one carton: 1-2515 Mast guy clamp 2-516GT Guy thimbles 1-2514GE Guy grip 1-20 ft. Coil of $\frac{1}{4}$ " guy wire 1-212GU Guy clamp 1-1258BTE $\frac{5}{8}$ x 12 Bent thimble c/w washer	7 lbs.	
2514 GK	OUTSIDE ONTARIO $\frac{1}{4}$ " Mast Guying Kit Contents in one carton: 1-2515 Mast guy clamp 2-516GT Guy Thimbles 1-2514GE Guy grip 1-20 ft. Coil of $\frac{1}{4}$ " guy wire 1-212GU Guy clamp 1-14GK Roof bracket 1-412LG $\frac{1}{2}$ " x 4"	6 lbs.	

Grounding Plates

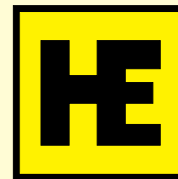

MAST AND ACCESSORIES

ONTARIO

Plates are required to be buried in soil, not in backfill adjacent to foundations.

Recommended location of Hydel Grounding Plates 1016 GPG & 1016 GPGC (c/w connector) in the Province of Ontario.

ATLANTIC

Note: Unless the meter has a separate ground lug as part of the neutral assembly, the ground conductor must connect to a neutral lug in the main switch or combination service entrance panel.

Please verify with your local inspection authority to check approval for their installation method.

Recommended locations of Hydel Grounding Plates 1016 GPGC (c/w connector) in the Province of New Brunswick and Nova Scotia.

Advantages / Disadvantages

Grounding Plates

- One grounding plate
- One ground connector
- Shallow pit required
- No power equipment required
- Ground plates are easy to carry and transport
- One ground plate weighs only 11 lbs. each
- Pit in which ground plate rests must remain open until inspection has taken place

Ground Rods

- Two ground rods
- Two connectors
- 10' rods can be very difficult and expensive to drive into the ground
- rods are long and awkward to transport
- Two rods – weight 30 lbs. (5/8 x 10)
- Ground rods can be inspected anytime after being installed

Ontario / Atlantic / British Columbia

CATALOGUE #	DESCRIPTION	PKG. QTY.	WT. EA.
1016.GPGC	1/4" x 10" x 16" plate c/w bronze grounding connector, #733.C, wire range #8 to 3/0	4	11.5 lbs.
1016.GPG	10" x 16" grounding plate less connector	4	11 lbs.

Alberta

CATALOGUE #	DESCRIPTION	PKG. QTY.	WT. EA.
1016 GPL	1/4" x 10" x 16" black plate	4	11 lbs.
1016 GPC	1/4" x 10" x 16" black plate, c/w connector	4	11.5 lbs.

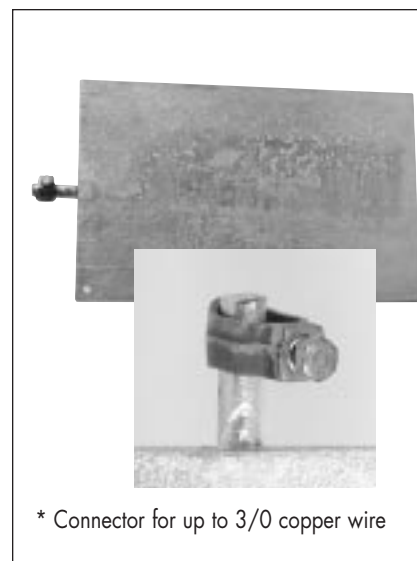

Poleline and Grounding



POLELINE & GROUNDING

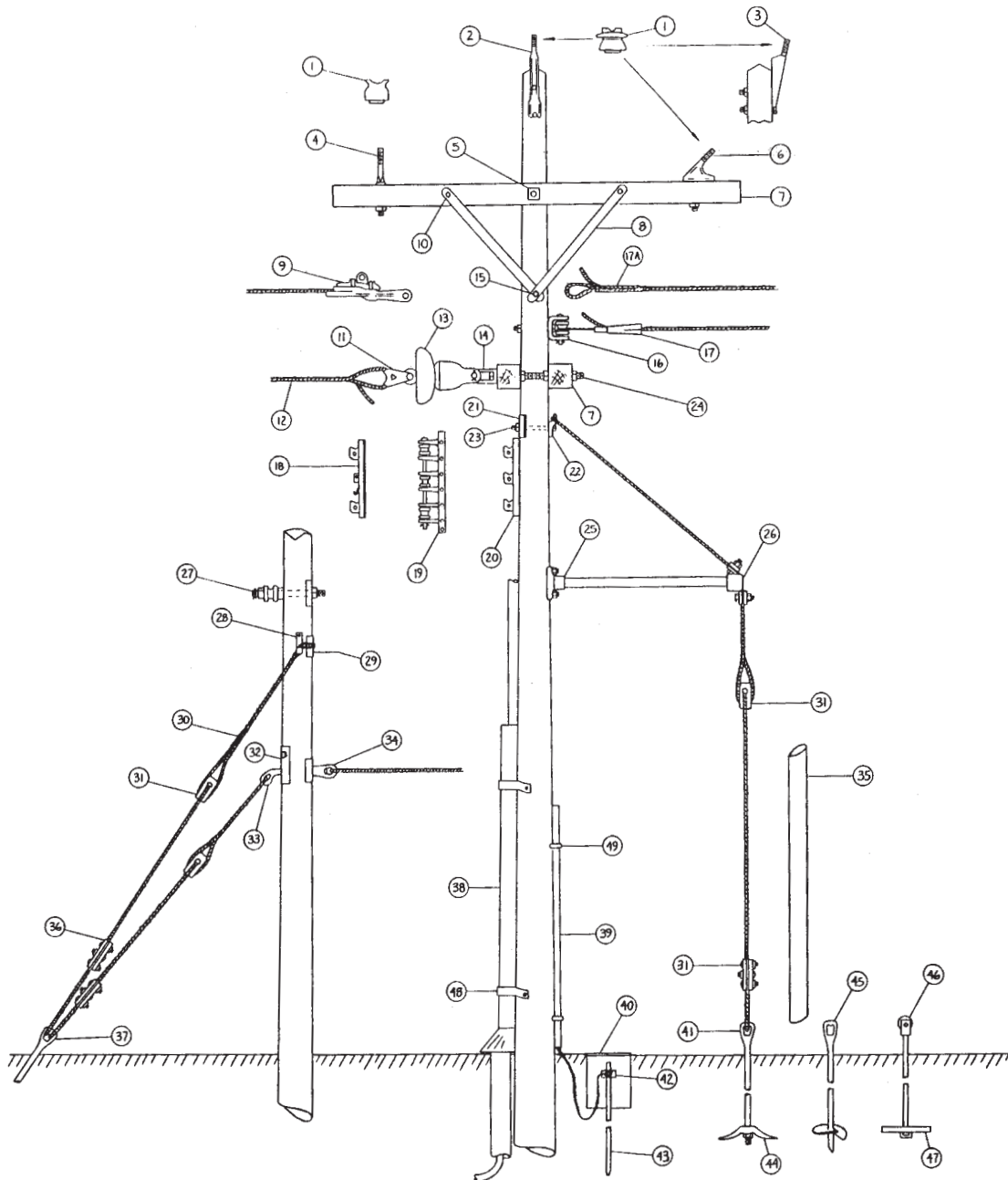

• For detailed information refer to our Poleline Catalogue

POLELINE AND GROUNDING

Galvanized Steel

Groundrods & Accessories



Bronze Ground Rod Connectors

CATALOGUE #	ROD SIZE	MAX. WIRE SIZE		QTY./PKG.	WT./LBS./C	
729C	5/8"	1/0	Str.Cu.	10	27	
733C	5/8" - 3/4"	3/0	Str.Cu.	50	23	
734C	3/4"	4/0	Str.Cu.	50	36	
710C	1"	250MCM	Str.Cu.	10	100	

CATALOGUE #	SIZE	PKG. QTY.	WT. LBS./C	
	Groundrods (Galv. Steel)			
1205G	1/2" x 5'	10	330	
1206G	1/2" x 6'	10	395	
1207G	1/2" x 7'	10	460	
5806G	5/8" x 6'	10	600	
5807G	5/8" x 7'	5	700	
5808G	5/8" x 8'	5	800	
5810G	5/8" x 10'	5	1000	
3406G	3/4" x 6'	5	900	
3408G	3/4" x 8'	5	1200	
3410G	3/4" x 10'	5	1500	
	Connectors (Galv. Steel)			
725	5/8"-3/4"	10	395	
714R	1/2"	10	460	
	Ground Electrode Inspection Box			
700	10" dia. x 12" deep (H.D. galv.)	5	1200	
724	10" dia. x 24" deep (H.D. galv.)	5	1200	
770	10" dia. x 12" deep (Galv. steel)	5	1200	
	Plastic Ground Wire Moulding & Staples			
701	1/2" plastic moulding x 8 ft.	12	6	
701W	1/2" wood moulding x 8 ft.		6	
702	2" x 1/2" staples x .162"	100	3	
703	2" x 13/16" staples x 3/16"	100	3	
704	3" x 1" staples x 5/16"	100	8	
705	3" x 1 1/2" staples x 1/4"	100	8	
707	1 1/4" x 3/8" staples x 1/4"	500	1	
708	2" x 1 1/16" staples x 3/16"	100	3	
709	3" x 1 1/16" staples x 1/4"	100	3	
	Gradient Control Mat			
6466GCM	6' x 4' Made from 6" x 6" welded mesh 1/4" dia. with pads for installation.	1	29	
6466GCC	6' x 4' 3 only grounding connectors 2/0 AWG 250 MCM	1	30	

POLELINE & GROUNDING

Copper Clad Groundrods and Connectors



CATALOGUE #	SIZE	WT./LBS./C	CATALOGUE #	SIZE	WT./LBS./C	
1205CC	1/2" x 5"	260	3406CC	3/4" x 6"	720	
1206CC	1/2" x 6"	305	3408CC	3/4" x 8"	960	
1208CC	1/2" x 8"	410	3409CC	3/4" x 9"	1080	
1210CC	1/2" x 10"	520	3410CC	3/4" x 10"	1200	
5805CC	5/8" x 5"	400	1008CC	1" x 8"	1700	
5806CC	5/8" x 6"	580	1010CC	1" x 10"	2130	
5808CC	5/8" x 8"	640				
5809CC	5/8" x 9"	740				
5810CC	5/8" x 10"	800				

Sectional Copper Clad Rods

CATALOGUE #	SIZE	WT./LBS./C	CATALOGUE #	SIZE	WT./LBS./C	
1208SC	1/2" x 8"	410	3408SC	3/4" x 8"	960	
1210SC	1/2" x 10"	510	3410SC	3/4" x 10"	1200	
5808SC	5/8" x 8"	640	1010SC	1" x 10"	2130	
5810SC	5/8" x 10"	800				

Couplings

Driving Studs

CATALOGUE #	SIZE	WT./LBS./C	CATALOGUE #	SIZE	WT./LBS./C	
12SC	1/2"	15	12DS	1/2"	15	
58SC	5/8"	26	58DS	5/8"	23	
34SC	3/4"	42	34DS	3/4"	35	
10SC	1"	85	10DS	1"	81	

Sectional copper clad rods are threaded at top and bottom. Two or more rods may be coupled together to make up the desired length. Threaded couplings are made of bronze. Driving studs are made of high strength carbon steel and are used to prevent damage to top-end threads or couplings. 1 stud required every 2 rods.

Bolts/Washers

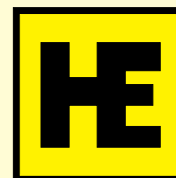

MACHINE BOLTS & WASHERS

CATALOGUE #	DIMENSIONS DIA.	"L"	"T"	STD. PKG.	WT. LB/C	CATALOGUE #	DIMENSIONS DIA.	"L"	"T"	STD. PKG.	WT. LB/C
612M	1/2"	6"	1 1/4"	25	45	1258M	5/8"	12"	6"	50	115
812M	1/2"	8"	4"	50	56	1458M	5/8"	14"	6"	50	130
1012M	1/2"	10"	4"	50	67	1658M	5/8"	16"	6"	50	145
1212M	1/2"	12"	6"	50	76	1858M	5/8"	18"	6"	50	160
658M	5/8"	6"	1 1/2"	50	70	1034M	3/4"	10"	6"	50	150
858M	5/8"	8"	4"	50	86	1234M	3/4"	12"	6"	50	175
1058M	5/8"	10"	6"	50	102	1434M	3/4"	14"	6"	25	200

See Poleline Catalogue for other sizes.

Minimum breaking strength at thread root:

1/2" dia. - 8500 lbs.

5/8" dia. - 13500 lbs.

3/4" dia. - 20000 lbs.

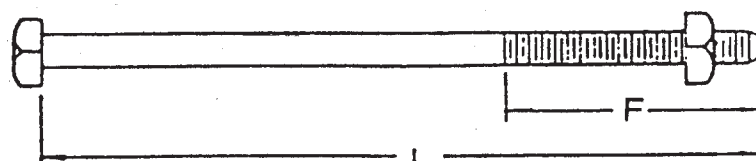

CATALOGUE #	DESCRIPTION	HOLE DIAMETER	STD. PKG	WT.	
	Square Washers				
1822SW-11	2" x 2" x 1/8"	11/16"	200	15	
3622SW-11	2" x 2" x 3/16"	11/16"	200	22	
3624SW-11	2 1/4" x 2 1/4" x 3/16"	11/16"	200	26	
3624SW-13	2 1/4" x 2 1/4" x 3/16"	13/16"	200	26	
1433SW-13	3" x 3" x 1/4"	13/16"	50	63	
1844SW-11	4" x 4" x 1/8"	11/16"	50	60	
3644SW-13	4" x 4" x 3/16"	13/16"	50	82	
1444SW-13	4" x 4" x 1/4"	13/16"	50	110	
	Curved Washers				
3624CW-13	2 1/4" x 2 1/4" x 3/16"	13/16"	100	26	
1433CW-13	3" x 3" x 1/4"	13/16"	50	60	
1434CW-13	3 1/4" x 3 1/4" x 1/4"	13/16"	50	75	
1444CW-13	4" x 4" x 1/4"	13/16"	50	110	
	Other sizes available upon request				
	Round Washers				
100RW	3/8" Bolt Size	7/16"	500	1.6	
114RW	9/16" Bolt Size	1/2"	500	3.0	
138RW	1/2" Bolt Size	9/16"	500	4.2	
134RW	5/8" Bolt Size	11/16"	500	8.4	
200RW	3/4" Bolt Size	13/16"	500	14.0	

POLELINE & GROUNDING

Steel Clevises



CATALOGUE #	DIMENSIONS			STEEL SECTION	DESCRIPTION	STD. PKG.	WT. LB/C
	"D"	"L"	"W"				
222CL	1 ¹ / ₁₆ "	2"	2 ¹ / ₄ "	11 ga x 1		38	38
414CL	1 ¹ / ₁₆ "	4 ¹ / ₄ "	2 ¹ / ₄ "	3 ¹ / ₁₆ " x 1 ¹ / ₂ "		25	100
517CL	1 ¹ / ₁₆ "	5 ¹ / ₄ "	3 ¹ / ₈ "	3 ¹ / ₁₆ " x 1 ¹ / ₂ "		25	120
212CNW	1 ¹ / ₁₆ "	2 ¹ / ₂ "	2 ¹ / ₄ "	3 ¹ / ₁₆ " x 1 ³ / ₄ "	Wet Insl.	25	140
314CL	1 ¹ / ₁₆ "	4"	3 ¹ / ₄ "	1 ¹ / ₄ " x 2		10	220
314CLU	1 ¹ / ₁₆ "	3"	3 ¹ / ₄ "	1 ¹ / ₄ " x 1 ¹ / ₂ "		25	180
114CL	1 ³ / ₁₆ "	2"	1 ¹ / ₄ "	3 ³ / ₈ " x 2"	Bolt Head Clevis	25	190
24236TC	—	2 ³ / ₁₆ "	3 ³ / ₄ "	10 ga.	"Pig's Ear" Tens. 10M# Yield 6M#	50	80
214CLB	1 ¹ / ₁₆ "	4 ³ / ₄ "	2 ¹ / ₄ "	11 ga & 1 ¹ / ₄	Swivel Clevis	25	105

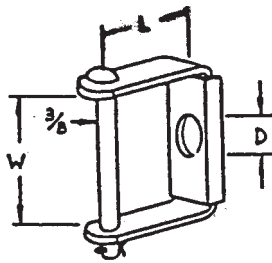

222.CL

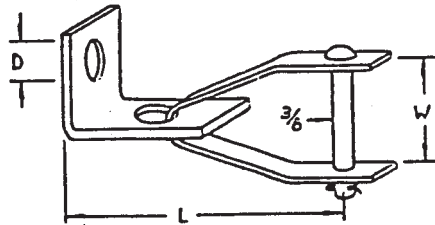

214.CLB

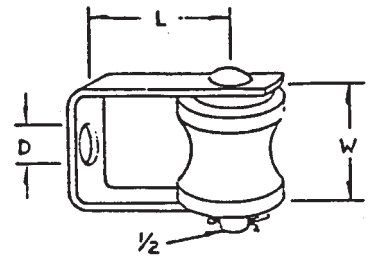

212.CNW

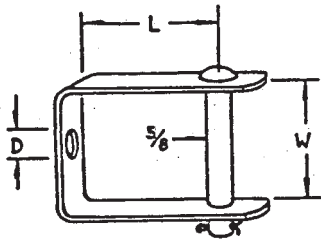

314.CL

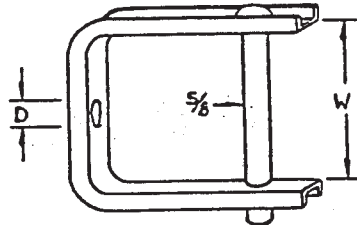

314.CLU

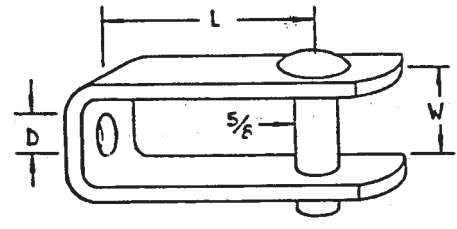

1316.CL

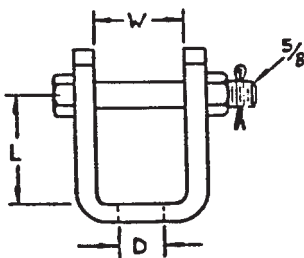

114.CL

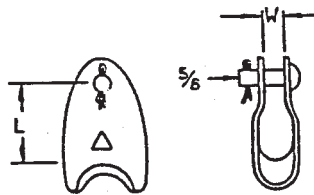

24236.TC

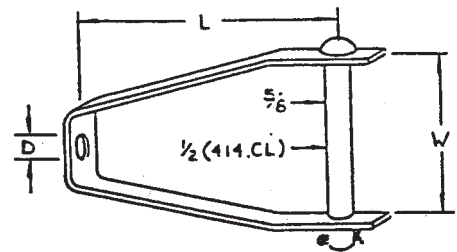

517.CL

POLELINE & GROUNDING

Wedge Grips/Insulator



CATALOGUE #	DIMENSIONS			STD. PKG.	WT. LB/C	
	DIA.	"L"	"T"			
14WG	1-4	1-4	2-6	50	17	W62AA
103WG	1/10-3	1-2	1/0-4	50	32	W20AA
4020WG	4/0 - 2/0	—	4/0 - 1/0	50	35	W40AA

Flexible bail available upon request



CATALOGUE #	DIMENSIONS				STD. PKG.	WT. LB/C	CLASS	STRENGTH IN LBS.
	"L"	"W"	"D"	"KV"				
1606WSP	2 ¹ / ₈ "	2 ¹ / ₄ "	1 ¹ / ₁₆ "	8	150	70	53-1	
355WSP	3"	2 ¹ / ₈ "	1 ¹ / ₁₆ "	12	50	126	53-2	
211D	3 ¹ / ₄ "	2 ¹ / ₈ "	1 ¹ / ₁₆ "	—	50	70	—	
502WGS	3 ¹ / ₂ "	2 ¹ / ₂ "	1 ¹ / ₁₆ "	—	40	120	54-1	10,000
504WGS	4 ¹ / ₄ "	2 ⁷ / ₈ "	—	4.4	40	170	54-2	12,000
506WGS	5 ¹ / ₂ "	2 ³ / ₈ "	—	6.6	20	210	54-3	20,000
451WGS	6 ³ / ₄ "	2 ¹ / ₂ "	—	6.6	20	455	54-4	20,000

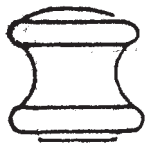

1606WSP

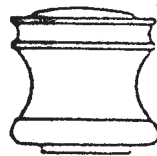

355WSP

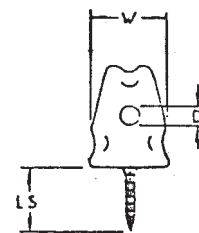

211D

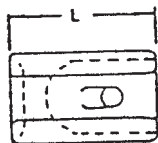

504WGS etc.



POLELINE & GROUNDING

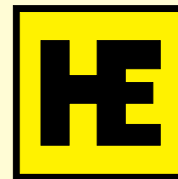

Double Arming Bolts

CATALOGUE #	DIMENSIONS	STD. PKG.	WT. LB/C	CATALOGUE #	DIMENSIONS	STD. PKG.	WT. LB/C
1458DA	5/8" x 14"	25	150	1434DA	3/4" x 14"	25	250
1658DA	5/8" x 16"	25	165	1634DA	3/4" x 16"	25	270
1858DA	5/8" x 18"	25	180	1834DA	3/4" x 18"	25	290
2058DA	5/8" x 20"	25	195	2034DA	3/4" x 20"	25	310
2258DA	5/8" x 22"	25	210	2234DA	3/4" x 22"	25	330
2458DA	5/8" x 24"	25	225	2434DA	3/4" x 24"	25	350



Lag Bolts

CATALOGUE #	DIMENSIONS	STD. PKG.	WT. LB/C	CATALOGUE #	DIMENSIONS	STD. PKG.	WT. LB/C
2514LG	1/4" x 2 1/2"	100	4	312LG	1/2" x 3"	50	19
356LG	5/16" x 3"	100	7	412LG	1/2" x 4"	50	25
2538LG	3/8" x 2 1/2"	50	10	512LG	1/2" x 5"	50	30
338LG	3/8" x 3"	50	11	612LG	1/2" x 6"	50	35
438LG	3/8" x 4"	50	14	458LG	5/8" x 4"	25	38
4538LG	3/8" x 4 1/2"	50	15	558LG	5/8" x 5"	25	46
638LG	3/8" x 6"	50	18	658LG	5/8" x 6"	25	54

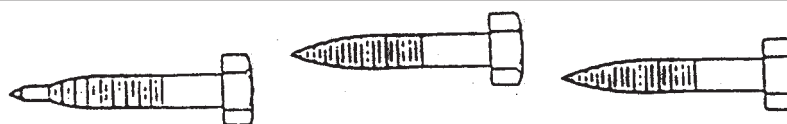

Guy Wire

CATALOGUE #	DIAMETER	GRADE & BREAKING STRENGTH LBS.				WT. LBS/C FT.	WT. LBS/C MTRS.
		50	110	160	180		
14GW	1/4"	1,800	3,950	5,750	6,450	12.9	42.31
516GW	5/16"	3,100	6,800	9,900	11,150	22.2	72.82
38GW	3/8"	3,750	8,250	12,000	13,500	27.0	88.56
716GW	7/16"	5,410	11,900	17,300	19,500	38.8	127.26
12GW	1/2"	7,100	15,600	22,700	25,500	51.0	167.28

Standard Coil and Spool Sizes Carried in Stock:

Spools: 5,000 ft. (1525 mtrs.); 2,500 ft. (762.5 mtrs.)

Coils: 500 ft. (152.5 mtrs.); 250 ft. (76.25 mtrs.) 100 ft.

When ordering, order by Cat No., length and grade. Please also specify *spool* or *coil*.

Prices vary only with diameter and grade, not with the size of the spool or coil.

Other grades, coils and diameters available on request.

A cutting charge applies to all special size spools and coils.



U-Cable Guards, Straps, Throat Clips



POLELINE &
GROUNDING

CATALOGUE # (STEEL)	CATALOGUE # (ALUMINUM)	DIMENSIONS "L" "W"		STD. PKG.	WT-LBS./C (STEEL)	WT-LBS./C (ALUMINUM)
Straight Cable Guards (UC & UCA)						
534UC	534UCA	5 ft.	3/4"	5	330	110
834UC	834UCA	8 ft.	3/4"	5	530	176
5114UC	5114UCA	5 ft.	1 1/4"	5	440	146
8114UC	8114UCA	8 ft.	1 1/4"	5	760	273
5214UC	5214UCA	5 ft.	2 1/4"	5	900	300
8214UC	8214UCA	8 ft.	2 1/4"	5	1300	433
5314UC	5314UCA	5 ft.	3 1/4"	5	1100	366
8314UC	8314UCA	8 ft.	3 1/4"	5	2000	666
5334UC	5334UCA	5 ft.	3 3/4"	3	1500	500
8334UC	8334UCA	8 ft.	3 3/4"	3	2160	720
8414UC	8414UCA	8 ft.	4 1/4"	3	2800	933
Flared Cable Guards (UCF & UFA)						
5114UCF	5114UFA	5 ft.	1 1/4"	5	460	153
8114UCF	8114UFA	8 ft.	1 1/4"	5	840	280
5214UCF	5214UFA	5 ft.	2 1/4"	5	930	31
8214UCF	8214UFA	8 ft.	2 1/4"	5	1300	443
5314UCF	5314UFA	5 ft.	3 1/4"	5	1540	513
8314UCF	8314UFA	8 ft.	3 1/4"	3	1850	620
8334UCF	8334UFA	8 ft.	3 3/4"	3	2450	816
8414UCF	8414UFA	8 ft.	4 1/4"	3	3010	1029
Straps (SUC & SCA)						
34SUC	34SCA	3/4" x 1/8"	3/4"	200	12	4
114SUC	114SCA	3/4" x 1/8"	1 1/4"	200	15	5
214SUC	214SCA	1" x 1/8"	2 1/4"	100	24	8
314SUC	314SCA	1" x 3/16"	3 1/4"	100	60	20
334SUC	334SCA	1" x 3/16"	3 3/4"	50	70	23
414SUC	414SCA	1" x 3/16"	4 1/4"	50	80	26
Aluminum Throat Clip (ATC)						
214ATC		used on 2 1/4" guard		50	—	25
314ATC		used on 3 1/4" guard		25	—	62
334ATC		used on 3 3/4" guard		25	—	69

For the protection of rising cable at the lower end of poles. Made from hot dip galvanized 14 ga. steel or 1100 grade aluminum to CSA dwg. no. G-3, Spec. C-83. Made in 2 styles: straight (UC & UCA) and flared (UCF & UFA). Flared design will fit over underground duct without the need of an adapter. Throat clips (ATC) to round off sharp edges at the top of cable guards are also available.

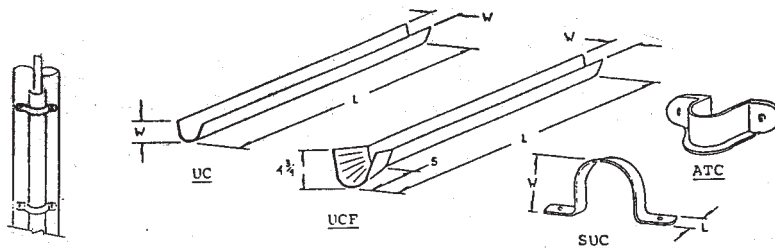

Commercial Enclosures



COMMERCIAL
ENCLOSURES

COMMERCIAL ENCLOSURES

Commercial Enclosures

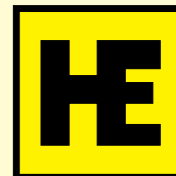

TYPE "D" & PULL BOXES

Type "D" Boxes – Screw-on

Standard Stock Cabinets with Screw-on Covers

- For surface or flush mounting. (1" overlap of cover for flush application).
- Grey baked enamel.
- Combination knockouts provided as standard.
- Special sizes available on request.
- Available with no KO's.



CATALOGUE #	DIMENSIONS	WEIGHT/LBS.
D 663	6" x 6" x 3"	3
D 664	6" x 6" x 4"	4
D 884	8" x 8" x 4"	5
D 886	8" x 8" x 6"	6
D 10104	10" x 10" x 4"	7
D 10106	10" x 10" x 6"	8
D 12124	12" x 12" x 4"	9
D 12126	12" x 12" x 6"	11
D 16166	16" x 16" x 6"	15
D 18186	18" x 18" x 6"	20
D 24246	24" x 24" x 6"	40

**Type "D" Custom Cabinets
(Screw on covers)
Other dimensions available on request
See Pull Boxes below**

Pull Boxes

Heavy gauge construction

- For surface or flush applications.
- Grey enamel finish.
- Special sizes available on request.

CATALOGUE #				DIMENSIONS
8" D	10" D	12" D	12" D	W X H
PB20208	PB202010	PB202012	PB202018	20" x 20"
PB24248	PB242410	PB242412	PB242418	24" x 24"
PB24368	PB243610	PB243612	PB243618	24" x 36"
PB30208	PB302010	PB302012	PB302018	30" x 20"
PB30308	PB303010	PB303012	PB303018	30" x 30"
PB36368	PB363610	PB363612	PB363618	36" x 36"
PB36488	PB364810	PB364812	PB364818	36" x 48"
PB 48488	PB484810	PB484812	PB484818	48" x 48"



COMMERCIAL ENCLOSURES

Commercial Enclosures



TYPE "E", "C" BOXES, TYPE "T" CABINETS

Type "C" Boxes

Custom Cabinets with Hinged Covers

- For surface mounting.
- Provision for locking.
- Grey baked enamel.
- Special sizes available on request.
- Specify suffix "NOKO" when no KO's required, i.e. C12126NOKO



Type "C" Custom Cabinets
(Hinged Covers)

Other dimensions available on request.

CATALOGUE #		DIMENSIONS
6" D	8" D	W X H
C12126	C12128	12" x 12"
C12186	C12188	12" x 18"
C16166	C16168	16" x 16"
C18186	C18188	18" x 18"
C24246	C24248	24" x 24"
C30306	C30308	30" x 30"



Type "E" Boxes - Hinged

Standard Stock Cabinets with Hinged Cover

- For surface mounting.
- Combination knockouts provided.
- Grey baked enamel.
- Special sizes available on request.

CATALOGUE #	DIMENSIONS	WEIGHT/LBS.
E 663	6" x 6" x 3"	3
E 664	6" x 6" x 4"	4
E 666	6" x 6" x 6"	4 1/2
E 684	6" x 8" x 4"	4 1/2
E 884	8" x 8" x 6"	5
E 1084	10" x 8" x 4"	6
E 10104	10" x 10" x 4"	7
E 10124	10" x 12" x 4"	8
E 12124	12" x 12" x 4"	9

Type "T" Cabinets (Telephone)

Standard Stock Cabinets of Rugged Construction

- For flush or surface mounting.
- Grey baked enamel.
- Screw-on front.
- Lock & Key standard.
- Special Sizes on Request.
- Wood Back - Specify WB.

CATALOGUE #			
4" D	6" D	8" D	DIMENSIONS
T12124	T12126	T12128	12" x 12"
T18124	T18126	T18128	18" x 12"
T18184	T18186	T18188	18" x 18"
T24184	T24186	T24188	24" x 18"
T24244	T24246	T24248	24" x 24"
T30244	T30246	T30248	30" x 24"
T36244	T36246	T36248	36" x 24"
T36304	T36306	T36308	36" x 30"
T36364	T36366	T36368	36" x 36"
T48484	T48486	T48488	48" x 48"



Above sizes are most popular stock sizes - for special dimensions or accessories please consult factory.

Commercial Enclosures

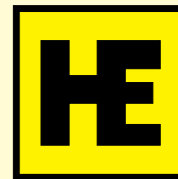

SPLITTER TROUGHS NEMA 1

Splitter Troughs 600V Maximum

CATALOGUE #		MAINS LUGS		BRANCH LUGS				DIMENSIONS			SHIP. WT. LBS.
3-WIRE	4 WIRE	AMP CU-AL	WIRE RANGE	MAX. AMP.		WIRE RANGE	QTY	INCHES			
				CU	AL			L	W	D	
ST203 ST303 ST403	ST204 ST304 ST404	85	14-1	55	40	14-6	6	24 36 48	6	4	13 17 20
ST213 ST313 ST413 ST513 ST613	ST214 ST314 ST414 ST514 ST614	125	14-2/0	110	85	14-1	6	24 36 48 60 72	6	4	13 17 20 25 30
ST223 ST323 ST423 ST523 ST623	ST224 ST324 ST424 ST524 ST624	225	6-300 MCM	175	135	14-2/0	6	24 36 48 60 72	8	5	21 26 36 42 48
ST343 ST443 ST543 ST643	ST344 ST444 ST544 ST644	400	Two 1/0 - 250 MCM One 3/0 - 600 MCM	175	135	6-3/0	6	36 48 60 72	10	6	43 54 65 77
ST463 ST563 ST663	ST464 ST564 ST664	600	Four 1/0 - 250 MCM Two 3/0 - 600 MCM	175	135	6 - 3/0	6	48 60 72	11	7	55 67 79

- Empty troughs available upon request
- See page 61 for splitter blocks



COMMERCIAL
ENCLOSURES

Commercial Enclosures



SPLITTER BOXES 600V & NEMA 3

CATALOGUE #		MAINS LUGS		BRANCH LUGS				DIMENSIONS			SHIP. WT. LBS.
3-WIRE	4 WIRE	AMP CU-AL	WIRE RANGE	MAX. AMP.		WIRE RANGE	QTY	INCHES			
				CU	AL			L	W	D	
SB003	SB004	85	14-1	55	40	14-6	3	12	12	4	6
SB013	SB014	125	14-2/0	110	85	14-1	3	12	12	4	9
SB023	SB024	225	6-300 MCM	175	135	14-2/0	3	16	16	5	16
SB043	SB044	400	One 3/0 - 600 MCM Two 1/0 - 250 MCM	285	230	6-350 MCM	2	22	22	6	44
SB063	SB064	600	Two 3/0 - 600 MCM	510	410	3/0-600 MCM	2	26	25	7	58

Available in Nema 3 enclosures upon request

- See page 62 for splitter blocks

EEMAC/NEMA 3 Cabinets

Raintight construction

- Slip on cover from stock
- Screw-on cover with gasket, add "SOC" to catalogue number upon request

CATALOGUE #	DIMENSIONS
STR644	6" x 4" x 4"
STR664	6" x 6" x 4"
STR884	8" x 8" x 4"
STR10104	10" x 10" x 4"
STR12124	12" x 12" x 4"
STR12126	12" x 12" x 6"
STR18126	18" x 12" x 6"
STR18186	18" x 18" x 6"
STR24186	24" x 18" x 6"



COMMERCIAL
ENCLOSURES

Commercial Enclosures

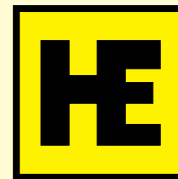

SPLITTER BLOCKS



Splitter Trough Block Assemblies

CATALOGUE #	BLOCKS	MAX./MIN. WIRE CAPACITY	BRANCHES		MAX./MIN. WIRE CAPACITY	SHIPPING WT.
			QTY	AMP		
T0	85	1 - 14	6	6/40	6 X (6 - 14)	1.0
T1	125	2/0 - 14	6	6/85	6 X (1 - 14)	1.0
T2	225	300* - 6	6	6/135	6 X (2/0 - 14)	1.2
T4	400	600* - 3/0 or 2 X (250* - 1/0)	6	6/135	6 X (3/0 - 6)	2.5
T6	600	2 X (600* - 3.0) 4 x (250* - 1/0)	6	6/135	6 X 3/0 - 6)	3.0

Application

These blocks are used in our standard splitters. They can be used for tapping branch circuits off feeders. All blocks are rated 600V.

Construction

- Cu-Al monopiece connectors secured to insulators
- Each block includes a main lug and branch lugs

On Special Order

- Copper connectors (Cu)
- Copper bars (Cu)



B0

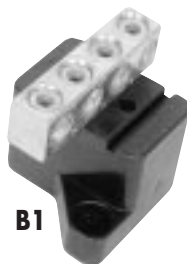

B1



B2



**B4
B6**

Splitter Block Assemblies

CATALOGUE #	MAINS AMPS	MAX./MIN. WIRE CAPACITY	BRANCHES		MAX./MIN. WIRE CAPACITY	SHIPPING WT.
			QTY	AMP		
B0	85	1 - 14	3	3/40	3 X (6 - 14)	0.8
B1	125	2/0 - 14	3	3/85	3 X (2/0 - 14)	0.8
B2	225	300* - 6	3	3/35	3 X (2/0 - 14)	1
B4	400	1 X (600* - 3/0) 2 X (250* - 1/0)	2	2/230	2 X (350* - 6)	2
B6	600	2 X (600* - 3.0)	2	2/410	2 X (600* - 3/0)	3

Commercial Enclosures



STANDOFF INSULATORS

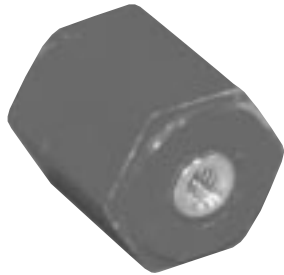

XGENP0007



XGENH0001



XGENH0005

CATALOGUE #	HEIGHT INCHES	DIAM. INCHES	RATED VOLTAGE	THREAD SIZE	TENSILE STRENGTH	CANTILEVER STRENGTH	COMPRESSION STRENGTH	WT. LBS
XGENP0007	1.250	1.000	600	1/4-20 x 1/4 deep	1000	400	8000	
XGENH0001	1.375	1.750	600	3/8-16 x 3/4 deep	2000	1500	20000	
XGENH0005	6.000	3.750	15000	3/8-16 x 3/4 deep	7500	1150	20000	

Fiberglass Reinforced Polyester Insulators

- Red colour
- Aluminum insert
- Specific voltage rating available on request

Commercial Enclosures



METER CABINETS

Meter Cabinets

Coil or Transformer Cabinets

- Standard stock cabinets with hinged doors.
- Supplied with pull catch and provision for padlocking.
- Knockouts standard.
- Grey enamel finish.
- Removable backplate standard.
- Special sizes available on request.



CATALOGUE #	DIMENSIONS H X W X D	KO'S	DOOR
MC271310	27" x 13" x 10"	1 1/2 / 2 / 2 1/2	Single
MC202010	20" x 20" x 10"	1 1/2 / 2 / 2 1/2	Single
MC302010	30" x 20" x 10"	1 1/2 / 2 / 2 1/2	Single
MC242410	24" x 24" x 10"	2 1/2 / 3	Single
MC303010	30" x 30" x 10"	2 1/2 / 3	Double
MC363612	36" x 36" x 12"	3 / 3 1/2	Double
MC484812	48" x 48" x 12"	3 / 3 1/2	Double

EEMAC/NEMA 3 Metering Cabinets

Rugged raintight construction.

- Vault handle.
- 3 Point Catch.
- Provision for padlocking.
- Formed heavy backplate.
- Gasketed.
- Dripshield installed.



CATALOGUE #	DIMENSIONS H X W X D	DOOR
3ST202010	20" x 20" x 10"	Single
3ST271310	27" x 13" x 10"	Single
3ST302010	30" x 20" x 10"	Single
3ST303010	30" x 30" x 10"	Double
3ST363612	36" x 36" x 12"	Double
3ST484812	48" x 48" x 12"	Double

NOTE: Hydel manufactures a variety of cabinetry for all applications, in all sizes. Contact our sales office for quotations to meet your requirements.

COMMERCIAL ENCLOSURES

Commercial Enclosures



LAY-IN DUCT NEMA 1

- For power and lighting installations.
- Fast installation and easy wiring.
- Secure and rugged construction provide electrical continuity and rigidity.
- Available with barrier for dual voltages.
- All hinged covers for conductor lay-in feature.
- Painted grey enamel finish.
- KO's provided as required.
- 1 inner sleeve installed in every length.



ITEM	DESCRIPTION	2 1/2" X 2 1/2" CATALOGUE #	4" X 4" CATALOGUE #	6" X 6" CATALOGUE #
Straight length including coupling	1 foot length	SD251	SD401	SD601
	2 foot length	SD252	SD402	SD602
	5 foot length	SD255	SD405	SD605
	10 foot length	SD250	SD400	SD600
Elbows	90°	SD2590	SD4090	SD6090
	45°	SD2545	SD4045	SD6045
	22 1/2°	SD2522	SD4022	SD6022
'T' Fitting	—	SD40T	SD60T	
Cross Fitting	—	SD25X	SD40X	SD60X
Reducer	4 x 4 to 2 1/2 x 2 1/2	—	SD42R	SD64R
	6 x 6 to 4 x 4	—	—	—
Closing plate	for connection to box	SD25C	SD40C	SD60C
Flange plate	for connection to box	SD25F	SD40F	SD60F
Inner sleeve	for connection to box	SD25IS	SD40IS	SD60IS
Hanger set	for vertical or horizontal	SD25H	SD40H	SD60H
Barrier	1'	SD21B	SD41B	SD61B
	2'	SD22B	SD42B	SD62B
	5'	SD25B	SD45B	SD65B
	10'	SD20B	SD40B	SD60B

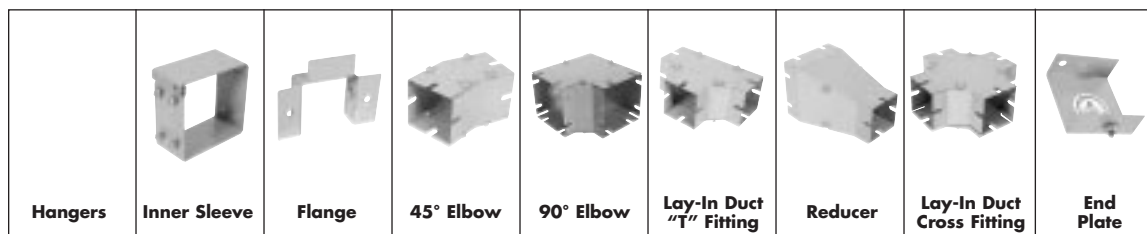

FITTINGS	LAY-IN DUCT FITTING DIMENSIONS								
	2 1/2" X 2 1/2"			4" X 4"			6" X 6"		
	A	B	C	A	B	C	A	B	C
Cross	6 1/2	—	—	8	—	—	11 1/2	—	—
'T'	6 1/2	4	—	8	6	—	11 1/2	8 3/4	—
90° Elbow	—	4	—	—	6	—	—	8 3/4	—
45° and 22° Elbow	—	—	3	—	—	3 1/2	—	—	4 1/2

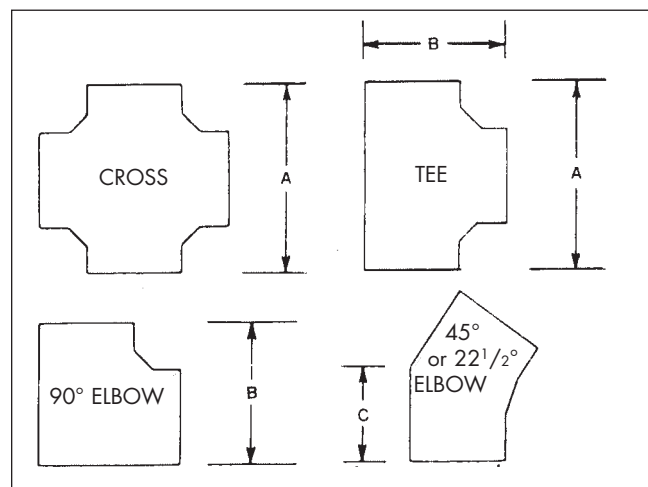

COMMERCIAL ENCLOSURES

Commercial Enclosures



CONTINUOUS BUSBAR TROUGHS CUSTOM MADE NEMA 1



Application

General purpose enclosure designed for indoor distribution. Plenty of wiring space and connection flexibility. Constructed of 12 gauge

- Padlockable cover, Hinged cover
- Available with aluminum or copper bus bars

How to Order:

Example - BBT800AL6F3W

BBT - Bus bar trough

800 - Current rating

AL - Aluminum / CU - Copper

6F - Length of trough in feet

3W - 3 wire / 4W - 4 wire

- All lug requirements must be specified, add suffix "L" to part number if required

MAINS CAPACITY AMP	TROUGH DIMENSIONS			
	3 WIRE		4 WIRE	
	H	D	H	D
225	19	7	19	7
400	19	7	21	7
600	19	7	21	7
800	19	7	23	8
1000	23	8	27	8
1200	23	8	27	8
1600	23	8	27	8
2000	25	10	30	10
2500	25	10	30	10

Technical Readout

CATALOGUE AMPERAGE	WIDTH INCHES	DEPTH INCHES	LENGTH (X) IN FEET									
			3	4	5	6	7	8	9	10	11	12
			WEIGHT IN LBS.									
225-3	13	5	36	46	57	66	76	117	131	—	—	—
400-3	19	7	63	102	124	142	164	192	214	242	—	—
600-3	19	7	74	120	147	167	193	226	252	285	306	332
800-3	19	7	74	120	147	167	193	226	252	285	306	332
1000-3	23	8	—	—	188	211	247	288	324	365	389	424
1200-3	23	8	—	—	188	211	247	288	324	365	389	424
1600-3	23	8	—	—	—	235	277	324	365	413	436	423
2000-3	25	10	—	—	—	313	332	389	439	501	522	572
2500-3	25	10	—	—	—	398	472	468	536	598	626	686
225-4	16	5	44	54	66	79	90	108	120	—	—	—
400-4	19	7	73	120	145	171	192	234	264	291	—	—
600-4	21	7	93	150	184	217	242	282	315	348	373	406
800-4	23	8	93	150	184	217	242	282	315	348	373	406
1000-4	27	8	—	—	234	277	305	237	402	453	481	525
1200-4	27	8	—	—	234	277	305	237	402	453	481	525
1600-4	27	8	—	—	—	317	345	406	457	517	445	597
2000-4	30	10	—	—	—	438	477	557	622	708	748	819
2500-4	30	10	—	—	—	524	569	662	748	842	887	974

Commercial Enclosures



CONTINUOUS BUSBAR TROUGH CONNECTORS

Main and Branch Lugs for Custom Busbar Troughs

NOMINAL CAPACITY	SINGLE LUG		DOUBLE LUG		TRIPLE LUG		QUADRUPLE LUG	
	CAT. #	CAPACITY MIN - MAX	CAT. #	CAPACITY MIN - MAX	CAT. #	CAPACITY MIN - MAX	CAT. #	CAPACITY MIN - MAX
35 Amps	35S	14 - 4	—	—	—	—	—	—
70 Amps	70S	14 - 2	—	—	—	—	—	—
125 Amps	125S	14 - 2/0	—	—	—	—	—	—
225 Amps	225S	6 - *300	—	—	—	—	—	—
400 Amps	400S	4 - *500	400D	6 - *250	—	—	—	—
600 Amps	600S	2 - *600	600D	6 - *350	600T	6 - *250	—	—
800 Amps	800S	*300 - *800	800D	2 - *600	800T	6 - *350	—	—
1000 Amps	1000S	*500 - *1000	1000D	*300 - *800	1000T	2 - *600	—	—
1200 Amps	—	—	1200D	*500 - *1000	1200T	2 - *600	—	—
1600 Amps	—	—	—	—	1600T	*300 - *800	—	—
2000 Amps	—	—	—	—	—	—	2000Q	6 - *350
2400 Amps	—	—	—	—	—	—	2400Q	2 - *600
3000 Amps	—	—	—	—	—	—	3000Q	*300 - *800

MCM * Nominal Capacity for certain cable type only. Basic price guide only. Copper lug price on request.

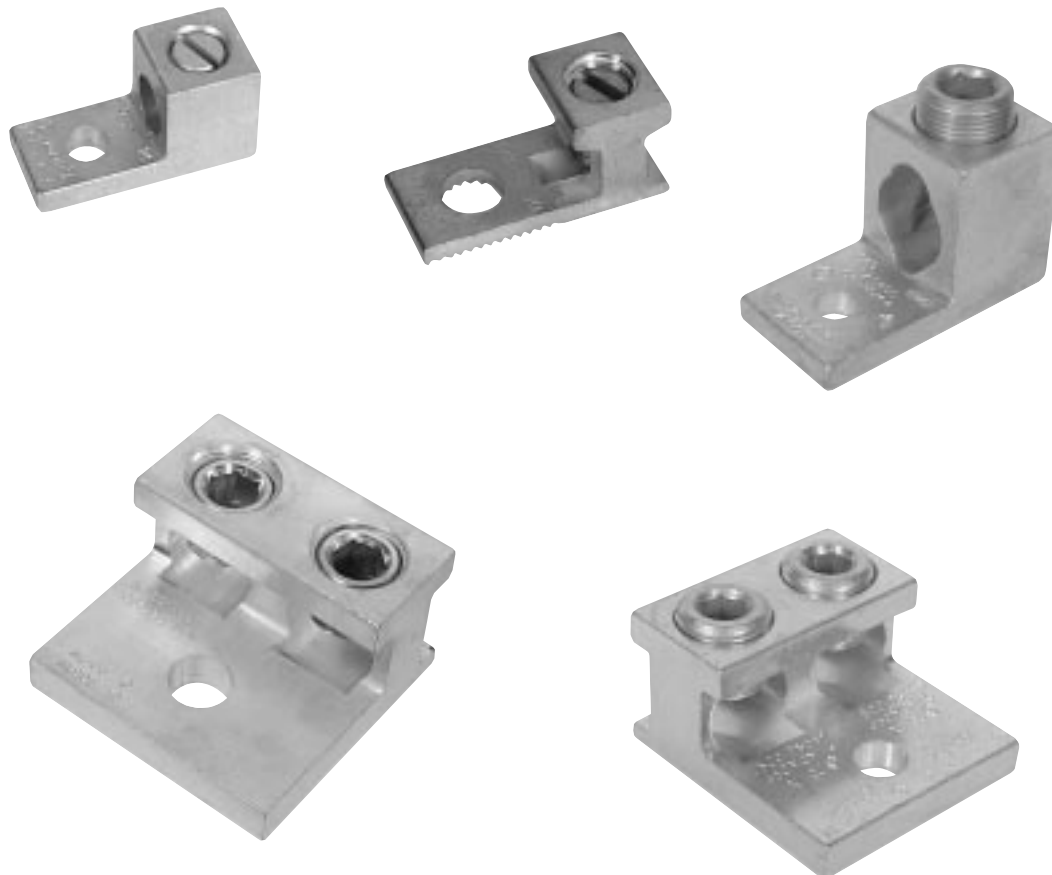

Commercial Enclosures



NEMA 1 ENCLOSURES

Quality Enclosures

EEMAC/NEMA Enclosures CSA Enclosure 1

Features

- Heavy duty 14 ga. spot welded construction.
- Backplates included.
- External mounting devices.
- Grey enamel finish.
- Hinged door.
- Provision for locking or sealing.

Application

General purpose indoor application. Quality enclosure for electrical controls or instrumentation.

CATALOGUE #				DIMENSIONS	
7" DEPTH	9" DEPTH	12" DEPTH	16" DEPTH	H X W	PANEL SIZE
IST16127	—	—	—	16" x 12"	14" x 10"
IST20167	—	—	—	20" x 16"	18" x 14"
IST20207	—	—	—	20" x 20"	18" x 18"
IST24207	IST24209	—	—	24" x 20"	22" x 18"
IST24247	IST24249	—	—	24" x 24"	22" x 22"
IST30207	IST30209	—	—	30" x 20"	28" x 28"
IST30247	IST30249	IST302412	—	30" x 24"	28" x 22"
IST36247	IST36249	IST362412	IST362416	36" x 24"	34" x 22"
—	IST36309	IST363012	IST363016	36" x 30"	34" x 28"
—	IST42249	IST422412	IST422416	42" x 24"	40" x 22"
—	—	IST423012	IST423016	42" x 30"	40" x 28"
—	—	IST423612	IST423616	42" x 36"	40" x 34"
—	—	IST483612	IST483616	48" x 36"	46" x 34"



COMMERCIAL ENCLOSURES

Industrial Enclosures



INDUSTRIAL
ENCLOSURES

INDUSTRIAL ENCLOSURES

Industrial Enclosures



SMALL - OIL, DUST & WATERTIGHT ENCLOSURES



Oil, Dust & Watertight EEMAC/NEMA 4/12

Features

- Oil & dust tight
- Watertight construction.
- Removable cover or piano hinged.
- All seam welded 14 ga. construction.
- Built to EEMAC/NEMA 4/12 requirements.
- Grey enamel finish.
- All complete with backplate.
- External wall mounting brackets.
- Neoprene gasketed.

Application

- For outdoor or indoor use.
- Suitable for electrical, control, or instrumentation housing.
- Completely weather resistant.
- For use in ship docks, construction sites, dairies, etc.
- Withstands water hose down.
- Suitable for terminal, transformer, or instrument or relay housing.
- Suitable as junction boxes or machinery wiring enclosures.

Also available in stainless steel and aluminum construction.

- All boxes available in stainless steel, 14 ga. type 304 construction - Suffix SSi.e. 4ST1084PHSS
- All boxes available in seam welded aluminum, utility grade 3/32" construction - Suffix AL, i.e. 4ST1084PHAL
- Also available are screw on cover enclosures - add prefix SOC, i.e. SOC4ST1084PH

CATALOGUE #	DIMENSIONS			PANEL SIZE
	H	W	D	
4ST443LOC	4"	4"	3"	NO PANEL
4ST443PH	4"	4"	3"	NO PANEL
4ST643LOC	6"	4"	3"	4.87" x 2.87"
4ST643PH	6"	4"	3"	4.87" x 2.87"
4ST644LOC	6"	4"	4"	4.87" x 2.87"
4ST644PH	6"	4"	4"	4.87" x 2.87"
4ST664LOC	6"	6"	4"	4.87" x 2.87"
4ST664PH	6"	6"	4"	4.87" x 2.87"
4ST864LOC	8"	6"	4"	6.87" x 4.87"
4ST864PH	8"	6"	4"	6.87" x 4.87"
4ST884LOC	8"	8"	4"	6.87" x 6.87"
4ST884PH	8"	8"	4"	6.87" x 6.87"
4ST1084LOC	10"	8"	4"	8.87" x 6.87"

CATALOGUE #	DIMENSIONS			PANEL SIZE
	H	W	D	
4ST1084PH	10"	8"	4"	8.87" x 6.87"
4ST1086LOC	10"	8"	6"	8.87" x 6.87"
4ST1086PH	10"	8"	6"	8.87" x 6.87"
4ST10104LOC	10"	10"	4"	8.87" x 8.87"
4ST10104PH	10"	10"	4"	8.87" x 8.87"
4ST12105LOC	12"	10"	5"	10.87" x 8.87"
4ST12105PH	12"	10"	5"	10.87" x 8.87"
4ST12126LOC	12"	12"	6"	10.87" x 10.87"
4ST12126PH	12"	12"	6"	10.87" x 10.87"
4ST14126LOC	14"	12"	6"	12.87" x 10.87"
4ST14126PH	14"	12"	6"	12.87" x 10.87"
4ST16146LOC	16"	14"	6"	14.87" x 12.87"
4ST16146PH	16"	14"	6"	14.87" x 12.87"

Industrial Enclosures

LARGE - OIL, DUST & WATER TIGHT



NEMA 4/12 c/w Hinged Cover

CATALOGUE #					DIMENSIONS	
6" DEPTH	8" DEPTH	10" DEPTH	12" DEPTH	16" DEPTH	H X W	PANEL SIZE
4ST12246	4ST12248	—	—	—	12" x 24"	9" x 21"
4ST16126	4ST16128	—	—	—	16" x 12"	13" x 9"
4ST16166	4ST16168	4ST161610	—	—	16" x 16"	13" x 13"
4ST16206	4ST16208	4ST162010	—	—	16" x 20"	13" x 17"
4ST20166	4ST20168	4ST201610	—	—	20" x 16"	17" x 13"
4ST20206	4ST20208	4ST202010	—	—	20" x 20"	17" x 17"
4ST20246	4ST20248	4ST202410	4ST202412	—	20" x 24"	17" x 21"
4ST24126	4ST24128	4ST241210	—	—	24" x 12"	21" x 9"
4ST24166	4ST24168	4ST241610	—	4ST241616	24" x 16"	21" x 13"
4ST24206	4ST24208	4ST242010	4ST242012	—	24" x 20"	21" x 17"
4ST24246	4ST24248	—	4ST242412	—	24" x 24"	21" x 21"
4ST24306	4ST24308	4ST243010	4ST243012	—	24" x 30"	21" x 27"
4ST30206	4ST30208	4ST302010	4ST302012	—	30" x 20"	27" x 17"
4ST30246	4ST30248	4ST302410	4ST302412	4ST302416	30" x 24"	27" x 21"
4ST30366	4ST30368	4ST303610	4ST303612	—	30" x 36"	27" x 33"
4ST36246	4ST36248	4ST362410	4ST362412	—	36" x 24"	33" x 21"
4ST36306	4ST36308	4ST363010	—	4ST363016	36" x 30"	33" x 27"
—	4ST42248	4ST422410	4ST422412	—	42" x 24"	39" x 21"
—	4ST42308	4ST423010	4ST423012	—	42" x 30"	39" x 27"
—	4ST42368	4ST423610	4ST423612	—	42" x 36"	39" x 33"
—	4ST48248	4ST482410	4ST482412	—	48" x 24"	45" x 21"
—	4ST48308	4ST483010	4ST483012	—	48" x 30"	43" x 27"
—	4ST48368	4ST483610	4ST483612	4ST483616	48" x 36"	45" x 33"
—	4ST60368	4ST603610	4ST603612	4ST603616	60" x 36"	57" x 33"
—	—	—	4ST723012	4ST723016	72" x 30"	69" x 27"
—	—	—	4ST723612	4ST723616	72" x 36"	69" x 33"

CATALOGUE #						DIMENSIONS	
8" DEPTH	10" DEPTH	12" DEPTH	16" DEPTH	20" DEPTH	24" DEPTH	H X W	PANEL SIZE
4ST54428	—	—	—	—	—	54" x 42"	51" x 39"
4ST60488	4ST604810	4ST604812	4ST604816	4ST604820	4ST604824	60" x 48"	57" x 45"
—	4ST606010	4ST606012	4ST606016	—	4ST606024	60" x 60"	57" x 57"
—	4ST726010	4ST726012	4ST726016	4ST726020	4ST726024	72" x 60"	69" x 57"
—	4ST727210	4ST727212	4ST727216	4ST727220	4ST727224	72" x 72"	69" x 69"



INDUSTRIAL ENCLOSURES

Industrial Enclosures



WIRING TROUGHS

EEMAC/NEMA 3 Wiring Troughs

Raintight Construction

- Splitter blocks mounted on standoffs
- Provision for sealing
- Drain hole provided



CATALOGUE #	DESCRIPTION			DIMENSIONS
	4TH WIRE	AMP.	LENGTH	
3ST22253	—	225	24"	8" x 4-1/2"
3ST32253	(4)	225	36"	
3ST42253	(4)	225	48"	
3ST34003	—	400	36"	10" x 6"
3ST44003	(4)	400	48"	
3ST54003	(4)	400	60"	
3ST64003	(4)	400	72"	
3ST56003	(4)	600	60"	11" x 7"
3ST66003	(4)	600	72"	

EEMAC/NEMA 4 & 12 Wiring Troughs

Rugged Gasketed Construction.

- Stainless steel clamps & outside screws
- Provision for sealing
- Built to EEMAC/NEMA 4 standards



CATALOGUE #	DESCRIPTION			DIMENSIONS
	4TH WIRE	AMP.	LENGTH	
ST22253	—	225	24"	8" x 4-1/2"
ST32253	(4)	225	36"	
ST42253	(4)	225	48"	
ST34003	—	400	36"	10" x 6"
ST44003	(4)	400	48"	
ST54003	(4)	400	60"	
ST64003	(4)	400	72"	
ST56003	(4)	600	60"	11" x 7"
ST66003	(4)	600	72"	

INDUSTRIAL ENCLOSURES

Industrial Enclosures



PUSHBUTTON ENCLOSURES

CATALOGUE #	HOLES	ENCLOSURE SIZE A X B X C
ST1PB	1	3 ¹ / ₂ " x 3 ¹ / ₄ " x 2 ³ / ₄ "
ST2PB	2	5 ³ / ₄ " x 3 ¹ / ₄ " x 2 ³ / ₄ "
ST3PB	3	8" x 3 ¹ / ₄ " x 2 ³ / ₄ "
ST4PB	4	10 ¹ / ₄ " x 3 ¹ / ₄ " x 2 ³ / ₄ "
ST4SPB	4	7 ¹ / ₄ " x 6 ¹ / ₄ " x 3"
ST5PB	5	12 ¹ / ₂ " x 3 ¹ / ₄ " x 2 ³ / ₄ "
ST6PBVL	6	14 ³ / ₄ " x 3 ¹ / ₄ " x 2 ³ / ₄ "
ST7PB	7	18" x 3 ¹ / ₄ " x 2 ³ / ₄ "
ST8PB	8	20 ¹ / ₄ " x 3 ¹ / ₄ " x 2 ³ / ₄ "
ST9PBVL	9	22 ¹ / ₂ " x 3 ¹ / ₄ " x 2 ³ / ₄ "
ST9PB	9	9 ¹ / ₂ " x 8 ¹ / ₂ " x 3"
ST10PB	10	24 ³ / ₄ " x 3 ¹ / ₄ " x 2 ³ / ₄ "
ST12PB	12	11 ³ / ₄ " x 8-1/2" x 3"
ST16PB	16	11 ³ / ₄ " x 10 ³ / ₄ " x 3"
ST20PB	20	14" x 10 ³ / ₄ " x 3"
ST25PB	25	14" x 13" x 3"

Oil & Dusttight Pushbutton Enclosures

- Built to EEMAC/NEMA 12 standards.
- All seam welded construction.
- Gasketed cover.
- Holes will receive all standard pushbuttons.
- External wall mounting flanges.
- ASA 61 Grey enamel finish.

For 4¹/₄" deep enclosures add 15% to prices indicated.

J.I.C. OIL TIGHT LAY-IN & PULL THROUGH WIREWAY

Rugged construction. 14 GA & 12 GA steel. All seams continuously welded & ground. All covers and flanges gasketed. Built to J.I.C. standards. Finished in ASA G1 Grey enamel or to suit.

CATALOGUE #			DESCRIPTION
2 ¹ / ₂ " X 2 ¹ / ₂ "	4" X 4"	6" X 6"	
ST2224	ST4424	ST6624	24" Straight Section
ST2260	ST4460	ST6660	60" Straight Section
ST22120	ST44120	ST66120	120" Straight Section
ST22J	ST44J	ST66J	Junction Box
ST229A	ST449A	ST669A	90° Elbow, Top Opening
ST229B	ST449B	ST669B	90° Elbow, Inside Opening
ST229C	ST449C	ST669C	90° Elbow, Outside Opening
ST2245A	ST4445A	ST6645A	45° Elbow, Top Opening
ST2245B	ST4445B	ST6645B	45° Elbow, Inside Opening
ST2245C	ST4445C	ST6645C	45° Elbow, Inside Opening
ST22A	ST44A	ST66A	Tee Fitting, Top Opening
ST22B	ST44B	ST66B	Tee Fitting, Outside Opening
ST22C	ST44C	ST66C	Cross Fitting
ST22P	ST44P	ST66P	Closure Plate
ST22BC	ST44BC	ST66BC	Box Connector
—	ST4422RE	—	Reducer 4" x 4" to 2 ¹ / ₂ " x 2 ¹ / ₂ "
—	—	ST6644RE	Reducer 6" x 6" to 4" x 4"
ST22H	ST44H	ST66H	Drop Hanger
ST22HB	ST44HB	ST66HB	Bracket Hanger

Pull Through add suffix (PTH). For Pricing contact our plant.



Ontario Hydro Enclosure

- Industrial Enclosures
- Custom Enclosures
- Steel - Aluminum -
Stainless Steel

Ask about Custom Built Enclosures

Industrial Busduct

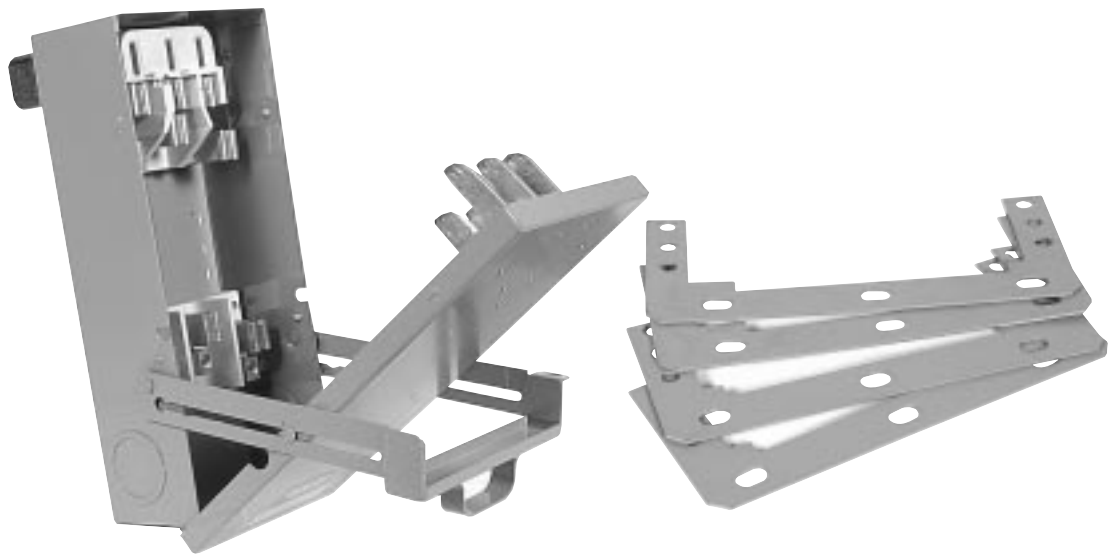

• Formerly known as Taylor

INDUSTRIAL BUSDUCT

BUSDUCT



TYPE "DE" FLEX-A-POWER PLUG-IN DUCT

FEATURES:

- Eight plug-in openings each side of a standard ten foot length.
- Provides power take-off every six inches throughout an installation.
- Joint covers on each side of a splice give easy access to all bus bar joints.
- Covers are interchangeable side for side.
- Side rail splice plate secured quickly and firmly by means of only two screws.
- Self tapping screws for greater convenience in making housing connections.
- Bus-bars are held firmly in the duct, there is no slippage when erected in a vertical position.
- Caliper type hanger facilitates and speeds installation.
- Finish is grey enamel.

GENERAL:

Type DE Flex-A-Power plug-in system is a safe, economical yet flexible system of power distribution and take off. Primarily designed for industrial and commercial buildings, it can be mounted either in a horizontal plane or vertically as a riser. All ratings are manufactured in standard 10 foot lengths but special sections can be made when required.

Each standard 10 foot section is provided with eight plug-in openings on each side at 12 inch centres. A power take off, by means of a Flex-A-Plug, may thus be made from either side of a run. Either fusible or circuit breaker type Flex-A-Plug are available.

All plug-in openings are equipped with rotating dust covers which provide protection from dust or moisture when the opening is not in use.

CURRENT RATINGS:

Copper - 250, 400, 600, 800 and 1000 amperes
Aluminum - 250, 400, 600, 800 amperes

VOLTAGE RATINGS:

- Up to 600 volts, 2 or 3 pole
- 120/208 volts, 3 phase, 4 wire, S.N.

SHORT CIRCUIT RATINGS:

- Up to 50,000 RMS amperes

Type DE Flex-A-Power is an easily expanded power system that will lend itself to any plant layout or machine alignment. It may also be used as a riser with plug-in power take-off at each floor. An entire installation may easily be removed and reinstalled in a new location.

CONSTRUCTION FEATURES:

HOUSING:

Type DE Flex-A-Power housing is manufactured from 16 gauge steel. The covers on each side are identical in all respects and are interchangeable side for side. The interlocking type of construction, coupled with overlapping splice plates at each joint, greatly increases the mechanical strength and rigidity of the assembly.

JOINT COVERS:

Identical joint covers are provided on each side of a splice. This permits easy access to both sides of a bus bar joint facilitating assembly.

BUS BARS:

Standard bus bars are high conductivity copper with the entire surface of each bar silver plated. Aluminum bus bars are available if specified. All bus bars are firmly held in place and do not require the addition of any other special supports when the duct is installed as a riser.

BUS BAR JOINTS:

All bus bar connections are bolted. Two special high tensile strength steel bolts in each bar ensure proper mechanical strength and electrical contact between surfaces. Lock washers are used to compensate for the difference in the co-efficient of heat between the steel bolts and bus bars.

BUS BAR SUPPORTS:

Bus bar supporting insulators are spaced on two foot centres. Made from shock resistant Electolite 5200-B having the highest dielectric strength, they eliminate the possibility of creepage or tracking.

HANGER ASSEMBLY:

two sets of supporting 'cradle' hangers are furnished with each standard ten foot length. These permit mounting of a Flex-A-Power run in either the flat or edgewise plane.

FINISH:

Standard finish is grey enamel.



TYPE "DE" FLEX-A-POWER BUS DUCT

GENERAL:

Furnish and install a Type DE Flex-A-Power Plug-in Bus Way System as manufactured by Hydrel and as shown on the drawings which form part of this specification.

This Flex-A-Power System shall be totally enclosed by a rigid steel housing. As many sections as possible shall be standard ten foot lengths. Special sections and/or fittings shall be provided only where necessary to suit the installation.

Plug-in access openings shall be provided on each side and staggered so as to provide a power take-off point every six inches in a ten foot section.

Each plug outlet shall be provided with an outlet cover plate. The shape of the outlets and the spacings of the bus bars shall permit insertion of plug-in units in only one position so as to assure maintenance of phase relation.

All equipment shall be listed and approved by C.S.A.

HOUSING:

The housing shall consist of standardized assemblies of form sixteen gauge sheet steel to provide a rigid enclosure. The form of the housing shall be such that a continuous molding is included along the entire length, providing a convenient method for attachment of Plug-in units and for attaching supporting hanger brackets. Each section shall be provided with internal splice plates for each side. These are to be attached at one end of the housing and arranged so that they telescope into the adjoining length to ensure alignment and increase the mechanical strength and rigidity of the assembly.

Removable joint covers shall be provided for each side of a joint to facilitate the bolting of the bus bars and simplify any required periodic inspections.

INSULATORS:

Bus bar insulators shall be spaced on a maximum of 24" centres and shall be shock resistant, non-tracking, non-carbonizing Electrolite 5200-B to provide high dielectric strength.

BUS BARS:

Bus bars shall be round edge, hand-drawn copper of 98% conductivity, (alternative - round-edge electrical conductor grade aluminum, D-50S with T-6 temper). Copper bus bars shall be silver plated by the silver cyanide immersion process. All contact surfaces of aluminum bus bars shall be Alston 70 tin plated. Joints shall be of the overlapping type with at least two 3/8" bolts passing through each. Bus bar joints shall incorporate lock washers to assure high contact pressure throughout the life of the system.

HANGERS:

Two "Cradle Type" Hangers shall be provided with each ten foot length so that the system shall be supported at least every five feet.

They shall be of such design that they may be mounted at any point along the run. The Hangers shall be suitable for flat or edgewise mounting.

PLUG-IN UNITS:

All Flex-A-Plug Units shall consist of sheet-steel housing with hinged covers which shall totally enclose the switching mechanism whether mounted on the bus-way or not. They shall be provided with adequate knock-outs and necessary clamps for quick attachment of the plug to the housing. Flex-A-Plug Units shall be equipped with high contact Phosphor Bronze Pressure Stabs to engage the bus bars. All copper parts shall be silver-plated. Solderless lugs shall be provided on all load terminals.

FINISH:

The housing for both type DE Flex-A-Power Plug-in Bus Way and Flex-A-Plug Units shall be finished in Grey Enamel over a rust inhibiting base.

Flex-A-Power



TYPE "DE" FLEX-A-POWER PLUG-IN DUCT

FITTINGS:

Type DE Flex-A-Power Fittings are basically the same construction as standard 10 foot lengths. Besides standard fittings, such as elbows and tees, special fittings and sections may be designed and fabricated to facilitate installations in difficult locations.

ELBOWS

Used to change the course of a run of Flex-A-Power 90 degrees in any direction in a flat or edgewise plane. Each leg of a standard elbow is 24 inches long but they may be manufactured in desired lengths to take up odd footage remaining in a run.

TEE CONNECTIONS

Manufactured for mounting in the flat or edgewise plane. They are required wherever it is necessary to "tap" into the main Flex-A-Power run with a branch run.

END BOXES

Close in the same end of a run of Flex-A-Power.

EXPANSION JOINTS

In extremely long runs, or where a run of DE Flex-A-Power crosses a building expansion joint, special Expansion joint Fittings are available to compensate for any difference in expansion or contraction between the building and the Flex-A-Power run.

CABLE TAP BOXES

Used where a run of Flex-A-Power is fed by conduit and wire or for power take-offs without overcurrent protection. Installed at joints between straight lengths or at the end of a run. When used at the end of a run, end boxes are required and should be ordered separately.

Type FE Fusible Flex-A-Plug

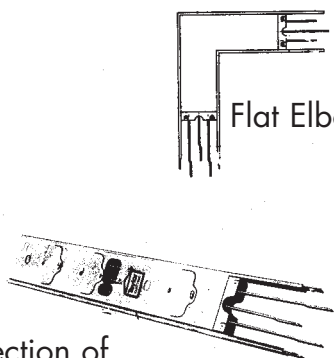
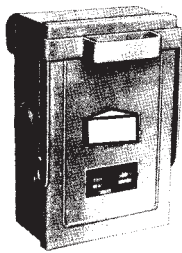

Standard Section of 250 amp Type de Flex-A-Power Showing Plug-in Opening and Dust Cover

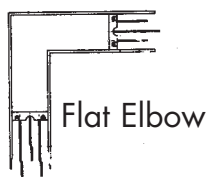

Flat Elbow

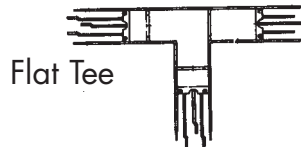

Flat Tee

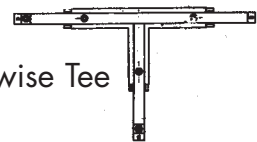

Edgewise Tee



Edgewise Elbow

Caliper Type Cradle Hanger

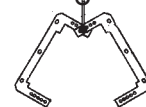

Bus Duct & Accessories



3 PHASE, 3 WIRE

3 Phase, 3 Wire 600V

AMPERE RATING	CU CAT. NO	AI CAT NO	CABLE TAP BOXES	END CLOSERS	HARDWARE KITS
250A	DEC 250-3	DEA250-3	DEB13	DEE13	DEH13
400A	DEC 400-3		DEB13	DEE13	DEH13
400A - 600A	DEC 600-3	DEA 400-3	DEB23	DEE 23	DEH23
600A - 800A	DEC 800-3	DEA 600-3	DEB33	DEE 33	DEH33
800A - 1000A	DEC 1000-3	DEA 800-3	DEB33	DEE 33	DEH33

3 Phase, 3 Wire 600V BUS DUCT

COPPER/CU CAT. #	AMP	WT/10 FT LENGTH (LBS.)	ALUMINUM/AI CAT. #	AMP	WT/10 FT LENGTH (LBS.)
DEC250-3	225	80	DEA250-3	225	66
DEC400-3	400	80	DEA400-3	400	81
DEC600-3	600	125	DEA600-3	600	95
DEC800-3	800	170	DEA800-3	800	103
DEC1000-3	1000	170			

Cable Tap Boxes*

CATALOGUE #	WT/LBS EA.
DEB13	38
DEB23	52
DEB33	64

End Closers

CATALOGUE #	WT/LBS EA.
DEE13	8
DEE23	8
DEE33	8

Hardware Kits**

CATALOGUE #	WT/LBS EA.
DEH13	8
DEH23	10
DEH33	13



* Cable Tap Boxes are for centre or end-of-run use. When used on end of a run, order end closer separately.

** One hardware kit is required with each ten foot length, part length, elbow or tee. Each hardware kit consists of two type "DE" hanger assemblies, joint hardware and joint covers.

Bus Duct & Accessories



3 PHASE, 4 WIRE

3 Phase, 4 Wire FCN up to 240V

AMPERE RATING	CU CAT. NO	AI CAT NO	CABLE TAP BOXES	END CLOSERS	HARDWARE KITS
250A	DEC 250-4	DEA 250-4	DEB14	DEE 13	DEH14
400A	DEC 400-4		DEB14	DEE 13	DEH14
400A - 600A	DEC 600-4	DEA 400-4	DEB24	DEE 23	DEH24
600A - 800A	DEC 800-4	DEA 600-4	DEB34	DEE 33	DEH34
800A - 1000A	DEC 1000-4	DEA 800-4	DEB34	DEE 33	DEH34

3 Phase, 4 Wire FCN up to 240V

COPPER/CU CAT. #	AMP	WT/10 FT LENGTH (LBS.)	ALUMINUM/AI CAT. #	AMP	WT/10 FT LENGTH (LBS.)
DEC250-4	225	96	DEA250-4	225	80
DEC400-4	400	96	DEA400-4	400	97
DEC600-4	600	150	DEA600-4	600	114
DEC800-4	800	204	DEA800-4	800	124
DEC1000-4	1000	204			

Cable Tap Boxes*

CATALOGUE #	WT/LBS EA.
DEB14*	42
DEB24*	57
DEB34*	70

End Closers

CATALOGUE #	WT/LBS EA.
DEE13	8
DEE23	8
DEE33	8

Hardware Kits**

CATALOGUE #	WT/LBS EA.
DEH14**	9
DEH24**	11
DEH34**	14



* Cable Tap Boxes are for centre or end-of-run use. When used on end of a run, order end closer separately.

** One hardware kit is required with each ten foot length, part length, elbow or tee. Each hardware kit consists of two type "DE" hanger assemblies, joint hardware and joint covers.

Flex-A-Power

TYPE "DE" FLEX-A-POWER PLUG-IN DUCT



DIMENSION DATA:

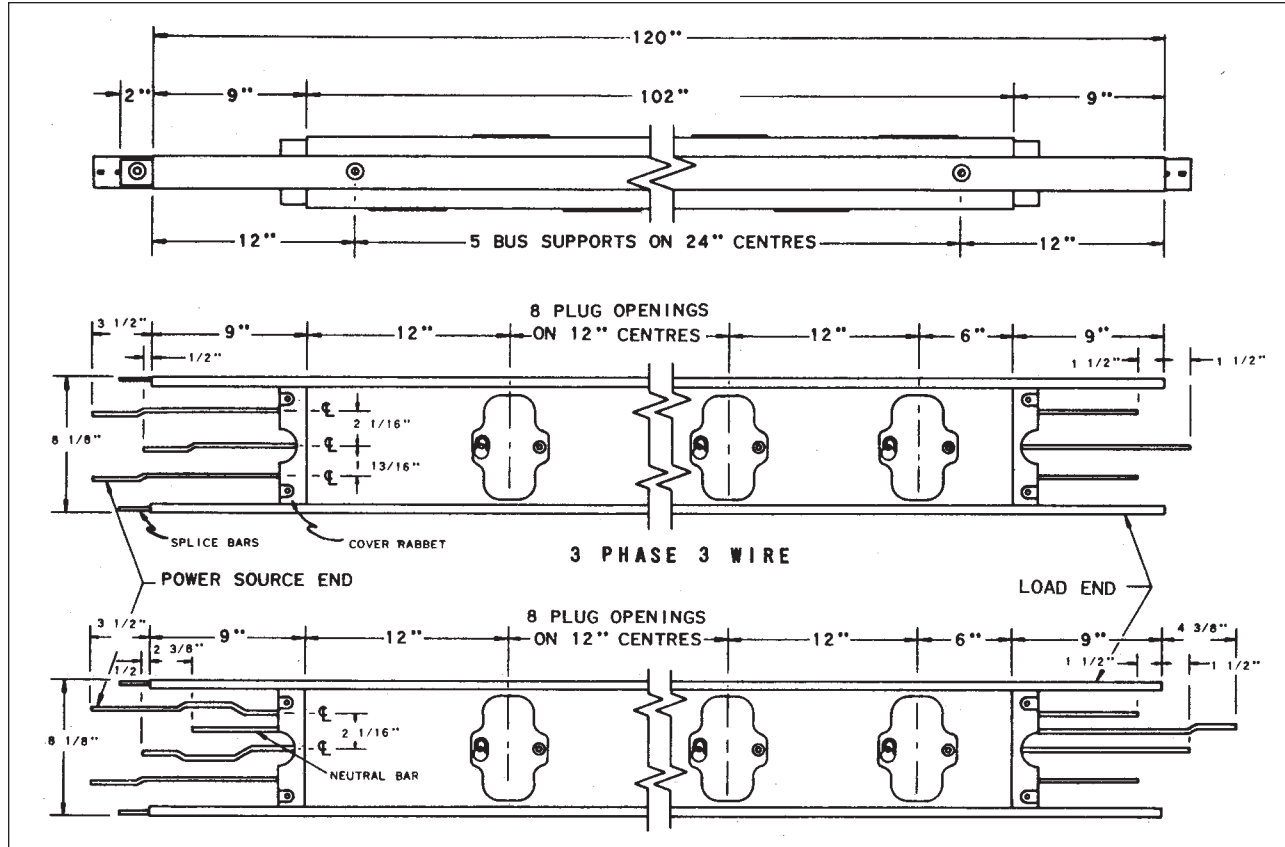

3-Phase, 4-Wire, Standard 10 foot lengths

Short Circuit Ratings: To 50,000 RMS Amps
 Voltage Ratings: Up to 600V, 2- or 3-Pole
 120/280V - 3-Phase, 4-Wire

Rating In Amps	No. of Poles	Copper/Alum. Bus Bars	Bus Bar, and Neutral Size	Approx. Wt. Lbs. Per Ft.	Dimensions Ins.		
					A	B	C
250	3	Copper	1/4 x 1 Tubular	7.3	1	3 ³ / ₁₆	1/2
250	3PH 4W	Copper	1/4 x 1 Tubular	7.8	1	3 ³ / ₁₆	1/2
400	3	Copper	1/4 x 1	8.5	1	3 ³ / ₁₆	1/2
400	3PH 4W	Copper	1/4 x 1	9.5	1	3 ³ / ₁₆	1/2
600	3	Copper	1/4 x 2	11.8	2	4 ³ / ₁₆	1
600	3PH 4W	Copper	1/4 x 2	13.7	2	4 ³ / ₁₆	1
800	3	Copper	3/16 x 4	16.6	4	6 ³ / ₁₆	2
800	3PH 4W	Copper	3/16 x 4	19.5	4	6 ³ / ₁₆	2
1000	3	Copper	1/4 x 4	19.4	4	6 ³ / ₁₆	2
1000	3PH 4W	Copper	1/4 x 4	12.5	4	6 ³ / ₁₆	2
250	3	Aluminum	1/4 x 1	6.7	1	3 ³ / ₁₆	1/2
250	3PH 4W	Aluminum	1/4 x 1	7.0	1	3 ³ / ₁₆	1/2
400	3	Aluminum	1/4 x 2	7.8	2	4 ³ / ₁₆	1
400	3PH 4W	Aluminum	1/4 x 2	8.4	2	4 ³ / ₁₆	1
600	3	Aluminum	3/16 x 4	10.5	4	6 ³ / ₁₆	2
600	3PH 4W	Aluminum	3/16 x 4	11.3	4	6 ³ / ₁₆	2
800	3	Aluminum	1/4 x 4	11.3	4	6 ³ / ₁₆	2
800	3PH 4W	Aluminum	1/4 x 4	12.5	4	6 ³ / ₁₆	2

BUSDUCT

Flex-A-Plugs



FE SERIES

Type "FE" - Cover Operated, Slow Make-Slow Break, Fusible Disconnect, Isolation Use Only - Most Commonly Used Style

600V, 3-Phase, 3-Wire

AMPERE RATING	CATALOGUE #	WT/LBS. EA.
30 A	FE5733	13
60 A	FE5736	13
100 A	FE57310	16
200 A	FE57320	41
400 A	FE57340	90

240V 3-Pole

AMPERE RATING	CATALOGUE #	WT/LBS. EA.
30 A	FE2333	13
60 A	FE2336	13
100 A	FE23310	16
200 A	FE23320	41
400 A	FE23340	90

120/208V, 3-Phase 4-Wire, SN

AMPERE RATING	CATALOGUE #	WT/LBS. EA.
30 A	FE2343SN	14
60 A	FE2346SN	14
100 A	FE23410SN	17
200 A	FE23420SN	42
400 A	FE23440SN	92

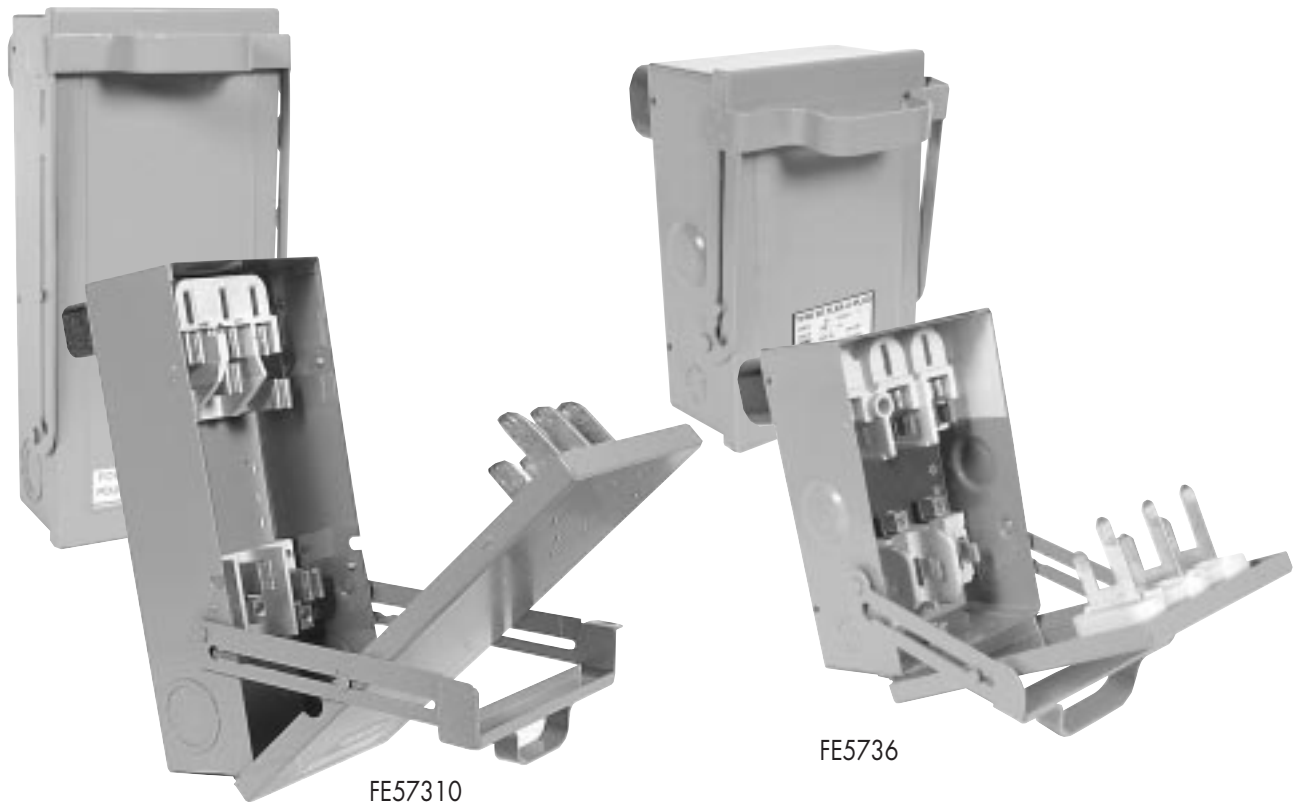

BUSDUCT

Flex-A-Plugs



FSF SERIES

Type "FSF" and "FVK" -- Handle Operated, Quick Mate-Quick Break, Cover Interlock, Fusible Switches

600V 3-Pole

AMP RATING	CAT. #	HP RATING	COND. HP	WT/LBS. EA.
30 A*	FSF5733	10	20	18
60 A*	FSF5736	20	50	18
100 A*	FSF57310	30	50	20
200 A*	FSF57320	50		36
400 A*	FSF57340			90
600 A	FVK366R c/w ext. pan			152

120/208V, 3-Phase 4-Wire, SN

AMP RATING	CATALOGUE #	WT/LBS. EA.
30 A	FSF5743SN	20
60 A	FSF5746SN	20
100 A	FSF57410SN	24
200 A	FSF57420SN	42
400 A	FSF57440SN	97
600 A	FVK366R + SN c/w ext. pan	160

240V 3-Pole

AMP RATING	CAT. #	HP RATING	COND. HP	WT/LBS. EA.
30 A	FSF2333	3	7 ¹ / ₂	18
60 A	FSF2336	7 ¹ / ₂	15	18
100 A	FSF23310	15	30	20
200 A	FSF23320	25	50	36
400 A	FSF23340			90
600 A	FVK326R c/w ext. pan			150

120/208V, 3-Phase 4-Wire, SN

AMP RATING	CATALOGUE #	WT/LBS. EA.
30 A	FSF2343SN	20
60 A	FSF2346SN	20
100 A	FSF23410SN	24
200 A	FSF23420SN	42
400 A	FSF23440SN	97
600 A	FVK326R + SN c/w ext. pan	160



Provision for Nema "J" HRC Fuses

Specify Exact Operating Voltage for ground detector and neutralizer plug, Catalogue # FEG3

Four Adjustable Clamp Hangers are supplied no charge with each Flex-a-plug.

BUSDUCT

Flex-A-Power

TYPE "DE" FLEX-A-POWER BUS DUCT



Cable Tap Box

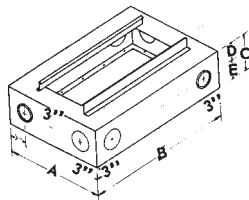

End Box

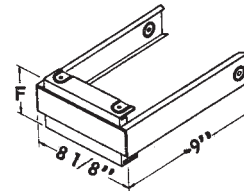

2- and 3-Poles and 3-Phase, 4-Wire

BOX	COPPER (DEC)		ALUMINUM (DEA)		DIMENSIONS					
SIZE	CABLE	LUGS	CABLE	LUGS	A	B	C	D	E	F
1	250/400	1-500 MCM	250	1-500 MCM	16	24	6	3	3	3 ³ / ₁₆ "
2	600	2-350 MCM	400	2-350 MCM	20	30	7 ¹ / ₂	4 ¹ / ₂	3	4 ³ / ₁₆ "
3	800/1000	3-500 MCM	600/800	3-500 MCM	20	36	8	4	4	6 ³ / ₁₆ "

Assembly Instructions

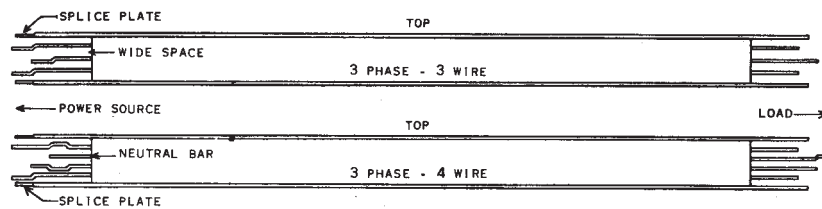

Figure 1

Type DE Flex-A-Power is packaged and shipped in sections which are assembled in a single run on the job site. With each section a hardware package is supplied which includes the necessary hangers, joint covers, bolts nuts and washers to make a complete joint between two sections.

Type DE Flex-A-Power Bus Duct may be hung horizontally in the "edgewise" or "flat" position or vertically as risers between floors etc. the usual

method is to mount the duct in the horizontal edgewise position.

Three phase-3 wire duct is mounted with the wide spacing between bars at the top. Three phase-4 wire duct is mounted with the neutral bar at the top.

In both 3 phase-3 wire and 3 phase-4 wire duct the end having the bars offset normally faces toward the power source and the straight bars toward the load. Flex-A-Power housings are clearly marked "TOP" and "SOURCE END".

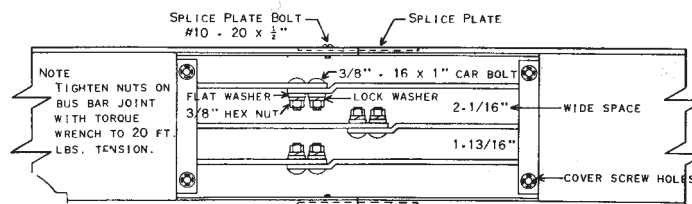

Figure 2

To connect two sections of DE Flex-A-Power together the sections should be located on the same plane and then pushed together. The splice plates on the side rail end of one section fit into the side rails of the second section and are bolted in place.

The straight bars must be located inside of the offset bars approximately 20 ft. lbs. torque is recommended. The joint covers are installed with 4 - 10/24 x 3/8 robertson head self-threading screw in each.

BUSDUCT

Flex-A-Power

TYPE "DE" FLEX-A-POWER BUS DUCT



Assembly Instructions

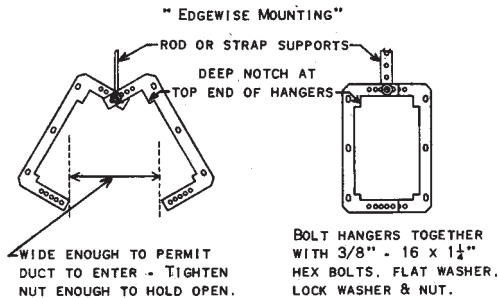

Figure 3

Figure 4

Hanger Rod or Straps should be installed and hangers attached with the bottoms open. (Figure 3). Duct can then be raised into position and hangers closed and bolted. (Figure 4) If desired, two or three lengths may be assembled together on the floor and raised into position as a single unit.

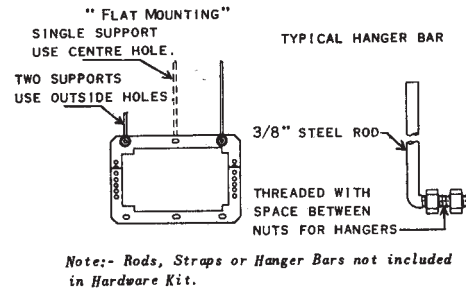

Figure 5

Figure 6

If duct is to hang in the flat horizontal position follow Figure 5.

DE Flex-A-Power in the vertical position (between floors etc.) should be installed with the neutral 9 or wide space) on the left when facing the side of the duct that plugs will be mounted on. Special J-hooks will be supplied on request only for hanging in this position.

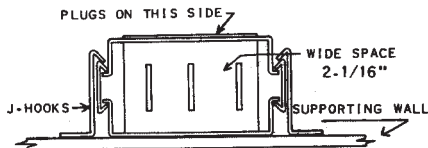

Figure 7

Flex-A-Plugs are completely self-aligning and cannot be incorrectly plugged into a run of Flex-A-Power due to the staggered spacing of the Flex-A-Power bus bars which assure correct phasing when a plug is connected.

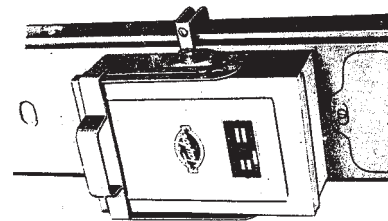

Figure 8

Clamp Hangers are supplied with each Flex-A-Plug to mechanically fasten it to the Flex-A-Power housing. Figure 8 shows a type FE Flex-A-plug secured to the duct by means of a Clamp Hanger.

BUSDUCT

Industrial Safety Switches



600V, HEAVY DUTY

Double Throw, Unfused Switches General Purpose Enclosures

With or Without Solid Neutral

- No Horse Power Rating
- Automatic Switching Not Available
- Cannot Operate Under Load
- Interlocks Not Available
- Not Service Entrance approved

2 Pole

	AMPS	CATALOGUE #	DIMENSIONS			WEIGHT LBS./EA.	CU. AL CONDUCTOR
			W"	H"	D"		
	30	SA5723DU	13.62	15.00	5.62	14	#14 - #2
	60	SA5726DU	13.62	15.00	5.62	14	#14 - #2
	100	SA57210DU	15.00	20.00	7.50	30	#14 - 1/0
	200	SA57220DU	19.00	26.00	9.00	50	#6 - 300 MCM
	400	SA57240DU	30.38	38.00	12.00	114	(1) #4 - 600 MCM (2) 1/0 - 250 MCM

2 Pole Solid Neutral

	AMPS	CATALOGUE #	DIMENSIONS			WEIGHT LBS./EA.	CU. AL CONDUCTOR
			W"	H"	D"		
	30	SA5733DUSN	13.62	15.00	5.62	17	#14 - #2
	60	SA5736DUSN	13.62	15.00	5.62	17	#14 - #2
	100	SA57310DUSN	15.00	20.00	7.50	34	#14 - 1/0
	200	SA57320DUSN	19.00	26.00	9.00	58	#6 - 300 MCM
	400	SA57340DUSN	30.38	38.00	12.00	150	(1) #4 - 600 MCM (2) 1/0 - 250 MCM

3 Pole

	AMPS	CATALOGUE #	DIMENSIONS			WEIGHT LBS./EA.	CU. AL CONDUCTOR
			W"	H"	D"		
	30	SA5733DU	13.62	15.00	5.62	19	#14 - #2
	60	SA5736DU	13.62	15.00	5.62	19	#14 - #2
	100	SA57310DU	15.00	20.00	7.50	40	#14 - 1/0
	200	SA57320DU	19.00	26.00	9.00	62	#6 - 300 MCM
	400	SA57340DU	30.38	38.00	12.00	156	(1) #4 - 600 MCM (2) 1/0 - 250 MCM

3 Pole Solid Neutral

	AMPS	CATALOGUE #	DIMENSIONS			WEIGHT LBS./EA.	CU. AL CONDUCTOR
			W"	H"	D"		
	30	SA5743DUSN	13.62	15.00	5.62	21	#14 - #2
	60	SA5746DUSN	13.62	15.00	5.62	21	#14 - #2
	100	SA57410DUSN	15.00	20.00	7.50	42	#14 - 1/0
	200	SA57420DUSN	19.00	26.00	9.00	65	#6 - 300 MCM
	400	SA57440DUSN	30.38	38.00	12.00	178	(1) #4 - 600 MCM (2) 1/0 - 250 MCM

SWITCHES
DOUBLE THROW

Industrial Safety Switches

600V, HEAVY DUTY



SA57420DUSN



SA5736DUSN

SWITCHES
DOUBLE THROW

Numerical Index



117	47	1206G	50	211D	54	3409CC	51	45T2424 - 6,8,12"	71	5808SC	51	C18188	59
122	47	1207G	50	212CNW	53	3410CC	51	45T2430 - 6,8,10,12"	71	5809CC	51	C24246	59
160	30	1208CC	51	213NSWMC	44	3410G	50	45T3020 - 6,8,10,12"	71	5810CC	51	C24248	59
215	30	1208SC	51	214ATC	56	3410SC	51	45T3024 - 6,8,10,12,16"	71	5810G	50	C30306	59
506	42	1210CC	51	214CLB	47	34DS	51	45T3036 - 6,8,10,12"	71	5810SC	51	C30308	59
700	50	1210SC	51	214SCA	56	34SC	51	45T3624 - 6,8,10,12"	71	58DS	51	CT4	29
701	50	1212M	52	214SUC	56	34SCA	56	45T3630 - 6,8,10,16"	71	58SC	51	CT4-2	29
702	50	1224M	52	217-U	47	34SUC	56	45T4224 - 8,10,12"	71	600-3	66	CT4-3	29
703	50	123LNSM	44	222-R	47	355WSP	54	45T4230 - 8,10,12"	71	600-4	66	CT4-4	29
704	50	123LNSWMC	45	222CL	53	356LG	55	45T4236 - 8,10,12"	71	600D	67	CT4-BC	29
705	50	123LNTFM	43	2234DA	55	35S	67	45T443LOC	70	600S	67	CT4-TS	29
707	50	123LNTMC	43	223HNSM	43	3622SW-11	52	45T443PH	70	600T	67	CTS	35
708	50	123NSM	44	223HNTFM	43	3624CW-13	52	45T4824 - 8,10,12"	71	612LG	55	CTS130	36
709	50	123NSWMC	44	223HNTWMC	43	3624SW-11	52	45T4830 - 8,10,12"	71	612M	52	CTS130PW	5
724	50	1258M	52	223LNSM	44	3624SW-13	52	45T4836 - 8,10,12,16"	71	638LG	55	CTS139	36
725	50	125S	67	223LNSWMC	45	3644SW-13	52	45T5442 - 8"	71	6466G0C	50	CTS139PW	5
729	50	12DS	51	223NSM	44	38GW	55	45T6036 - 8,10,12,16"	71	6466GCM	50	CTS400PW	5
770	50	12GW	55	223NSWMC	44	35T202010	64	45T6048 - 8,10,12,16,20,24"	71	658LG	55	CTS405PW	5
2145	47	12SC	51	225-3	66	35T271310	64	45T6060 - 10,12,16,24"	71	658M	52	CTS408PW	4
2501	42	130A	28	225-4	66	35T302010	64	45T643LOC	70	701W	50	CTS409	36
2502	42	134RW	52	2258DA	55	35T303010	64	45T643LOC	70	70S	67	CTS409PW	4
2504	41	138RW	52	225S	67	35T363612	64	45T643PH	70	710C	50	CTS459PW	4
2505	41	1433CW-13	52	2400Q	67	35T484812	64	45T644LOC	70	714R	50	CTS500PW	5
2506	41	1433SW-13	52	24236TC	53	3WT22253	72	45T644PH	70	716GW	55	CTS800	36
2508	42	1434CW-13	52	2434DA	55	3WT2253	72	45T664LOC	70	733C	50	CTS800PW	5
2509	42	1434DA	55	2458DA	55	3WT34003	72	45T664PH	70	734C	50	D10104	58
2510	42	1434M	52	2500-200UR	45	3WT42253	72	45T7230 - 12,16"	71	800-3	66	D10106	58
2512	42	1444CW-13	52	2500-3	66	3WT44003	72	45T7236 - 12,16"	71	800-4	66	D12124	58
2513	41	1444SW-13	52	2500-4	66	3WT54003	72	45T7260 - 10,12,16,20,24"	71	800D	67	D12126	58
2515	41	1458DA	55	2500200MCR	45	3WT56003	72	45T7272 - 10,12,16,20,24"	71	800T	67	D16166	58
2516	41	1458M	52	2500MCR	45	3WT64003	72	45T864LOC	70	8114UC	56	D18186	58
2521	41	14GW	55	2500UR	45	3WT66003	72	45T864LOC	70	8114UCF	56	D24246	58
2525	42	14WG	54	2502MS	42	4000N	46	45T864PH	70	8114UFA	56	D663	58
2550	42	1600-3	66	2504-12	41	400D	67	45T864PH	70	8114UFA	56	D664	58
5061	42	1600-4	66	2504-6	41	400S	67	45T884LOC	70	812M	52	D884	58
1000-3	66	1600T	67	2504-LB	41	4020WG	54	45T884PH	70	8214UC	56	D886	58
1000-4	66	1606WSP	54	2506-3	41	412LG	55	502WGS	54	8214UCA	56	DEA250-3	79
1000D	67	1634DA	55	2506N	41	414CL	53	504WGS	54	8214UCF	56	DEA250-4	80
1000S	67	1658DA	55	2506N2	41	414SCA	56	506-5/8	42	8214UFA	56	DEA400-3	79
1000T	67	1658M	52	2506NB	41	414SUC	56	5061M	42	8314UC	56	DEA400-4	80
1008CC	51	1822SW-11	52	2507-5/8"	42	438LG	55	506M	42	8314UCA	56	DEA600-3	79
100MA	46	1834DA	55	2514GK	47	451WGS	54	506WGS	54	8314UCF	56	DEA600-4	80
100RW	52	1844SW-11	52	2514LG	55	4538LG	55	5114UC	56	8314UFA	56	DEA800-3	79
100SF	46	1858DA	55	2516-L	41	458LG	55	5114UCA	56	8334UC	56	DEA800-4	80
1010CC	51	1858M	52	2516-L4	41	45T10104LOC	70	5114UCF	56	8334UCA	56	DEB13	79
1010SC	51	15T16127	68	2517-U	41	45T10104PH	70	5114UFA	56	8334UCF	56	DEB14	80
1012M	52	15T20167	68	2518-U	41	45T1084LOC	70	512LG	55	8334UFA	56	DEB23	79
1016GPC	48	15T20207	68	2521-2	41	45T1084PH	70	516GW	55	834UC	56	DEB24	80
1016PGP	48	15T2420 - 7,9"	68	2526NB	41	45T1086LOC	70	517QL	53	834UCA	56	DEB33	79
1016PGC	48	15T2424 - 7,9"	68	2538LG	55	45T1086PH	70	5214UC	56	8414UC	56	DEB34	80
1016GPL	48	15T3020 - 7,9"	68	25516GK	47	45T12105LOC	70	5214UCA	56	8414UCA	56	DEC1000-3	79
1034M	52	15T3024 - 7,9,12"	68	25C	41	45T12105PH	70	5214UCF	56	8414UCF	56	DEC1000-4	80
103WG	54	15T3624 - 7,9,12,16"	68	3000Q	67	45T12126LOC	70	5214UFA	56	8414UFA	56	DEC250-3	79
1058M	52	15T3630 - 7,12,16"	68	312LG	55	45T12126PH	70	5314UC	56	858M	52	DEC250-4	80
10DS	51	15T4224 - 9,12,16"	68	314ATC	56	45T1224 - 6,8"	71	5314UCA	56	AD100	33	DEC400-3	79
10SC	51	15T4230 - 12,16"	68	314CL	53	45T14126LOC	70	5314UCF	56	AD500	33	DEC400-4	80
113NSWMC	45	15T4236 - 12,16"	64	314CLU	53	45T14126PH	70	5314UFA	56	B0	61	DEC600-3	79
114CL	53	15T4836 - 12,16"	68	314SCA	56	45T1612 - 6,8"	71	5334UC	56	B1	61	DEC600-4	80
114RW	52	2000-3	66	314SUC	56	45T16146LOC	70	5334UCA	56	B2	61	DEC800-3	79
114SCA	56	2000-4	66	334ATC	56	45T16146PH	70	534UC	56	B4	61	DEC800-4	80
114SUC	56	2000N	46	334SCA	56	45T1616 - 6,8,10"	71	534UCA	56	B6	61	DEE13	79
1200-3	66	2000Q	67	334SUC	56	45T1620 - 6,8,10"	71	558LG	55	C12126	59	DEE13	80
1200-4	66	200MA	46	338LG	55	45T2016 - 6,8,10"	71	5805CC	51	C12128	59	DEE23	79
1200D	67	200RW	52	3406CC	51	45T2020 - 6,8,10"	71	5806CC	51	C12186	59	DEE23	80
1200T	67	200SF	46	3406G	50	45T2024 - 6,8,10,12"	71	5806G	50	C12188	59	DEE33	79
1205CC	51	2014U	41	3408CC	51	45T2412 - 6,8,10"	71	5807G	50	C16166	59	DEE33	80
1205G	50	2034DA	55	3408G	50	45T2416 - 6,8,10,16"	71	5808CC	51	C16168	59	DEH13	79
1206CC	51	2058DA	55	3408SC	51	45T2420 - 6,8,10,12"	71	5808G	50	C18186	59	DEH14	80