

SD Series

100 AMP - MULTI POSITION



CATALOGUE #	DESCRIPTION	METER POSITIONS	ENCLOSURE SIZE A X B X C	WEIGHT
SD220PW	2 gang, 200 Amp main, 100 Amp per position	2	15" x 12" x 5"	20 lbs.
SD320PW	3 gang, 200 Amp main, 100 Amp per position	3	22 ¹ / ₂ " x 12" x 5"	28 lbs.
SD420PW	4 gang, 200 Amp main, 100 Amp per position	4	30" x 12" x 5"	36 lbs.
SD520PW	5 gang, 200 Amp main, 100 Amp per position	5	37 ¹ / ₂ " x 12" x 5"	44 lbs.
SD620PW	6 gang, 200 Amp main, 100 Amp per position	6	45" x 12" x 5"	52 lbs.
SD220PWBC	1 - 3" KO in bottom	2	17 ¹ / ₂ " x 15" x 5"	23 lbs.

- Factory bussed - 200 Amp Mains
- 2 - 6 position horizontal
- 4 Jaw meter sockets
- 100 Amp - 600 VOLTS per position
- CSA enclosure 3
- Approved conductor range:
Line No. 6-250 MCM CU/AL
Load No. 6-1/0 AWG CU/AL
- Approved for overhead or underground use

- Field adaptable accessories
- 5th Jaw at 9 O'clock - SXK503
- For overhead order "SXC" hub separate
- Add suffix "RH" for right hand entry

KNOCKOUT CODE	CONDUIT SIZE
D	1 ¹ / ₄ ", 1 ¹ / ₂ ", 2"
G	1 ¹ / ₄ ", 1 ¹ / ₂ ", 2", 2 ¹ / ₂ "
AA	1 ¹ / ₂ "

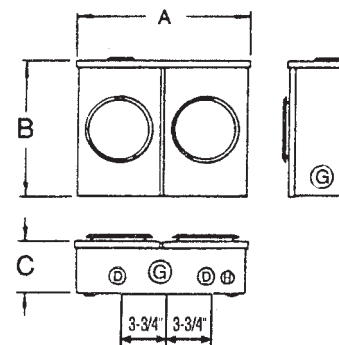

SD220 Conversion Kit

To convert existing SD220PW to a two load single meter, meter socket ST911 - OH