



### Square Head Machine Bolts complete with Nuts

Bolts 6" and longer made with buffer points. C.S.A. Standard Drawing No. B-3.

Minimum breaking strength at thread root:

3/8" diameter – 4,650 lbs.

1/2" diameter – 8,500 lbs.

5/8" diameter – 13,500 lbs.

3/4" diameter – 20,000 lbs.

Cat. No.	L	T	Std.Pkg.	Wt.-lbs./ C
<b>3/8" Diameter Bolts complete with Hexagon Nuts:</b>				
1538M	1-1/2	1	100	10
238M	2	1	100	11
2538M	2-1/2	1	100	12
338M	3	1	100	13
438M	4	1	50	15
538M	5	1	50	19
638M	6	1	50	22
<b>1/2" Diameter Bolts complete with Square Nuts:</b>				
1512M	1-1/2	1-1/4	50	18
212M	2	1-1/4	50	21
312M	3	1-1/4	50	28
412M	4	1-1/4	25	35
512M	5	1-1/4	25	40
612M	6	1-1/4	25	45
712M	7	1-1/4	25	50
812M	8	4	50	56
1012M	10	4	50	67
1212M	12	6	50	76
1412M	14	6	50	85
1612M	16	6	50	94

Other sizes available upon request.

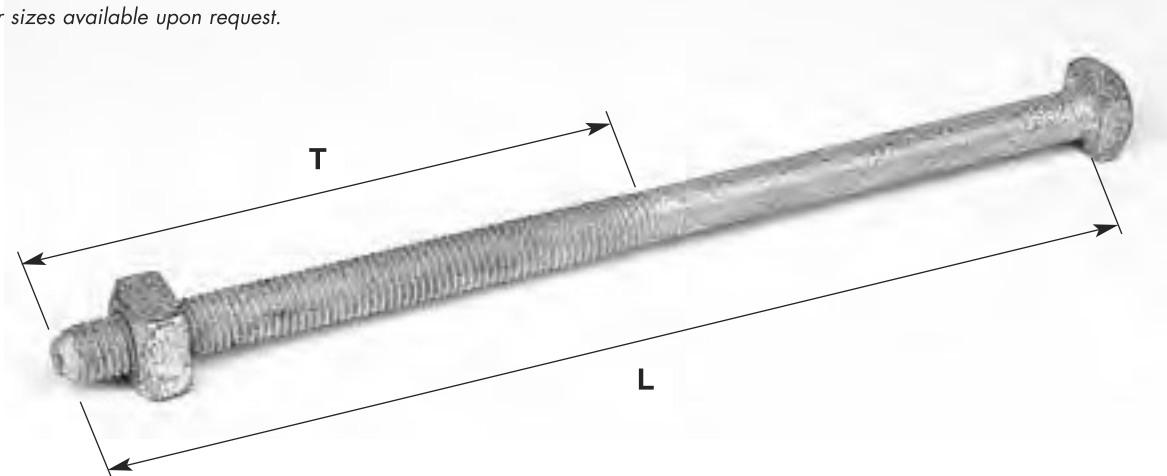

1258M



# Bolts

## MACHINE BOLTS

### Square Head Machine Bolts complete with Square Nuts *Cont'd*

Cat.No.	L	T	Std. Pkg.	Wt.-lbs./ C
<b>5/8" Diameter Bolts:</b>				
258M	2	1-1/2	25	38
358M	3	1-1/2	25	45
458M	4	1-1/2	25	54
558M	5	1-1/2	25	62
658M	6	1-1/2	50	70
858M	8	4	50	86
1058M	10	4	50	102
1058M-8	10	8	50	102
1258M	12	6	50	115
1458M	14	6	50	130
1658M	16	6	50	145
1858M	18	6	25	160
2058M	20	6	25	175
2258M	22	6	25	190
2458M	24	6	25	208
2658M	26	6	25	226
2858M	28	6	25	235
<b>3/4" Diameter Bolts:</b>				
634M	6	1-3/4	50	102
834M	8	4	50	130
1034M	10	4	50	150
1234M	12	6	50	175
1434M	14	6	25	200
1634M	16	6	25	225
1834M	18	6	25	245
2034M	20	6	25	270
2234M	22	6	25	300
2434M	24	6	25	320
2634M	26	6	25	340

Other sizes available upon request.

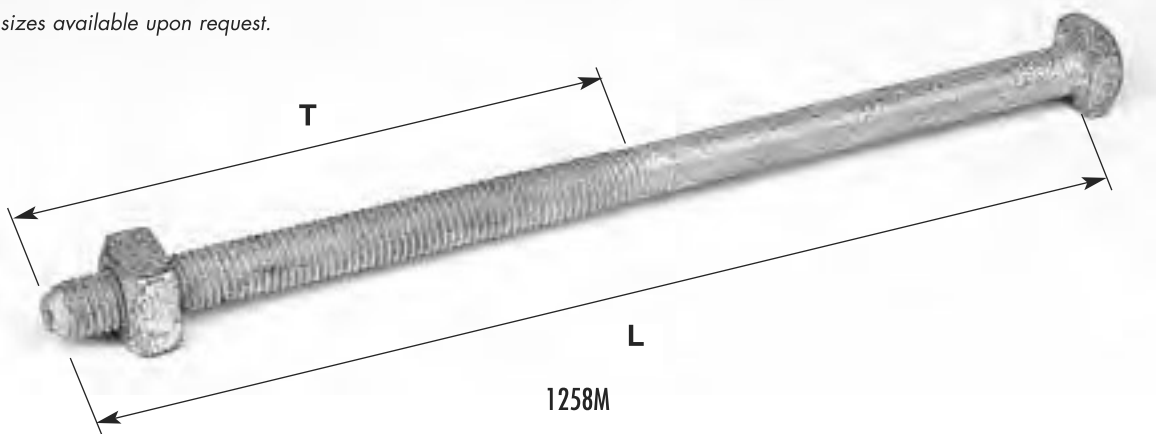



### Carriage Bolts

Hot dip galvanized complete with hexagon nuts. C.S.A. Drawing B-33.

Cat.No.	Dimensions			Std.Pkg.	Wt.-lbs./C
	(D)iameter	(L)ength	(T)hread Length		
<b>3/8" Diameter Minimum Breaking Strength 4,500 lbs.</b>					
1538CB	3/8	1-1/2	1/2	50	12
2538CB	3/8	2-1/2	1	50	14
3538CB	3/8	3-1/2	1	50	15
438CB	3/8	4	1	50	16
4538CB	3/8	4-1/2	1	50	17
538CB	3/8	5	1	50	19
5538CB	3/8	5-1/2	1	50	20
638CB	3/8	6	1 1/4	50	22
<b>1/2" Diameter Minimum Breaking Strength 8,500 lbs.</b>					
412CB	1/2	4	1-1/4	50	32
4512CB	1/2	4-1/2	1-1/4	20	33
512CB	1/2	5	1-1/4	20	35
5512CB	1/2	5-1/2	1-1/4	20	38
612CB	1/2	6	1-1/2	20	42
<b>5/8" Diameter Minimum Breaking Strength 13, 500 lbs.</b>					
358CB	5/8	3	1-1/2	25	46
4558CB	5/8	4-1/2	1-1/2	25	58
658CB	5/8	6	1-3/4	25	70
1058CB	5/8	10	1-3/4	25	102
1258CB	5/8	12	1-3/4	25	115

Other sizes available upon request.

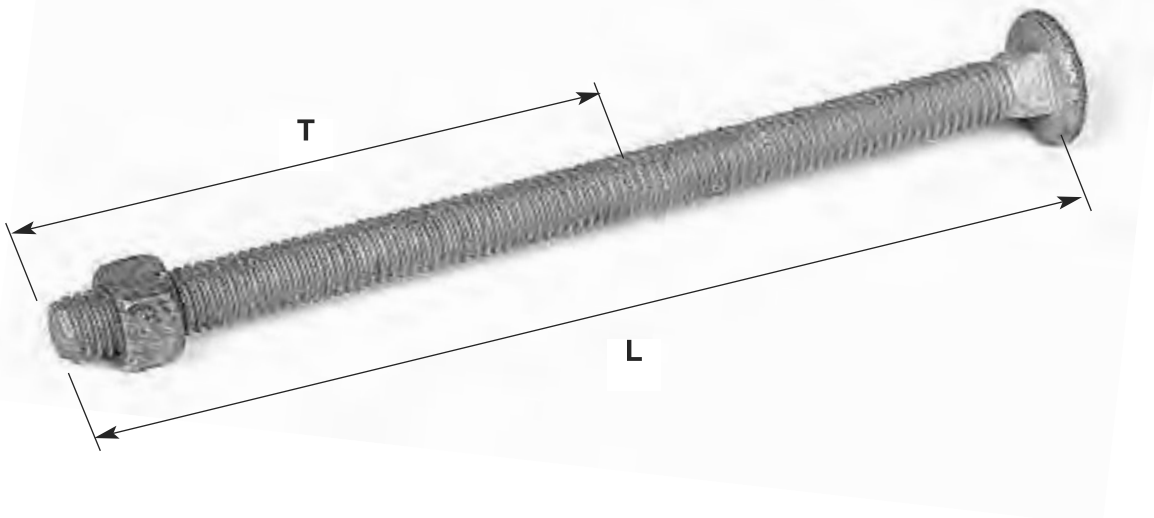



# Bolts

## DOUBLE ARMING BOLTS

### Double Arming Bolts

Fully threaded, Hot dip galvanized, buffer points. C.S.A. Standard Drawing No. B-2.

Minimum breaking strength at thread root:

5/8" diameter – 13, 500 lbs.

3/4" diameter – 20, 000 lbs.

Cat.No.	Size	Std.Pkg.	Wt.-lbs./ C
1058DA	5/8 x 10"	25	120
1258DA	5/8 x 12"	25	135
1458DA	5/8 x 14"	25	150
1658DA	5/8 x 16"	25	165
1858DA	5/8 x 18"	25	180
2058DA	5/8 x 20"	25	195
2258DA	5/8 x 22"	25	210
2458DA	5/8 x 24"	25	225
2658DA	5/8 x 26"	25	240
2858DA	5/8 x 28"	25	255
3058DA	5/8 x 30"	25	270
1034DA	3/4 x 10"	25	210
1234DA	3/4 x 12"	25	230
1434DA	3/4 x 14"	25	250
1634DA	3/4 x 16"	25	270
1834DA	3/4 x 18"	25	290
2034DA	3/4 x 20"	25	310
2234DA	3/4 x 22"	25	330
2434DA	3/4 x 24"	10	350
2634DA	3/4 x 26"	5	370
2834DA	3/4 x 28"	5	390
3034DA	3/4 x 30"	5	410

Other sizes available upon request.



1658DA



## THIMBLE & OVAL EYE BOLTS

### Thimble Eye Bolts

Complete with square nuts. Hot dip galvanized, cone points. C.S.A. Drawing No. B-7 & B-5

Cat. No.	D	L	T	Std. Pkg.	Wt.-lbs./ C
<b>Straight</b>					
858TE	5/8	8	6	25	125
1058TE	5/8	10	6	25	144
1258TE	5/8	12	6	25	162
1458TE	5/8	14	6	25	198
<b>Bent Thimble Eye Bolts</b>					
1058BTE	5/8	10	6	25	144
1258BTE	5/8	12	6	25	162
1458BTE	5/8	14	6	25	198
1010BTE	1	10	6	10	190



1058TE



1058BTE

### Oval Eye Bolts

Hot dip galvanized Bolts 6" and longer have cone points.

Eye Dimensions (A x B) for 1/2" bolt: 1 x 1-1/2; for 5/8 and 3/4" bolts: 1-1/2 x 2

Cat.No.	Diameter	L	T	Std.Pkg.	Wt.-lbs./ C
6580E	5/8	6	3	50	122
8580E	5/8	8	4	50	136
10580E	5/8	10	4	25	150
12580E	5/8	12	6	25	168
14580E	5/8	14	6	25	186
16580E	5/8	16	6	25	204
18580E	5/8	18	6	25	222
20580E	5/8	20	6	25	250
22580E	5/8	22	6	25	270
24580E	5/8	24	6	25	290
10340E	3/4	10	6	25	225
12340E	3/4	12	6	25	250
14340E	3/4	14	6	25	275
16340E	3/4	16	6	25	295
18340E	3/4	18	6	25	320

Other sizes available upon request.



10580E



# Bolts

## "U" BOLTS

### "U" Bolts

Complete with 4 hexagon nuts. Minimum order quantities required.

Cat. No.	Dimensions-Inches				Minimum Breaking Strength	Std.Pkg.	Weight/100
	Size A-Inches	B	C	D			
6310U	3/8	2-5/8	2-1/16	1	8,000 lbs.	100	35
6320U	3/8	3-1/8	2-5/16	1	8,000 lbs.	100	40
6330U	3/8	4	2-13/16	1-1/2	8,000 lbs.	100	47
6421U	1/2	2-1/2	1-1/2	1-1/4	14,000 lbs.	100	63
6451U	1/2	3	1-1/2	1-1/4	14,000 lbs.	100	71
6461U	1/2	4	2	1-1/2	14,000 lbs.	100	84
6551U	5/8	3	1-1/2	1-3/4	25,000 lbs.	50	122
6552U	5/8	3-5/8	1-3/4	2	25,000 lbs.	50	132
6555U	5/8	4	2	2	25,000 lbs.	50	142
6661U	3/4	4-1/2	3	2-1/2	36,000 lbs.	25	220
6663U	3/4	5-1/2	2-3/8	2-1/2	36,000 lbs.	25	250
6665U	3/4	6	2-3/8	2-1/2	36,000 lbs.	25	295
6750U	7/8	5	2-1/2	2-1/2	50,000 lbs.	15	364
6760U	7/8	6	2-3/4	3	50,000 lbs.	15	405
6770U	7/8	7	3	3	50,000 lbs.	15	446
6850U	1	5	3	2-1/2	66,000 lbs.	10	507
6860U	1	6	3-1/8	3	66,000 lbs.	10	560
6870U	1	7	3-1/4	3	66,000 lbs.	10	613

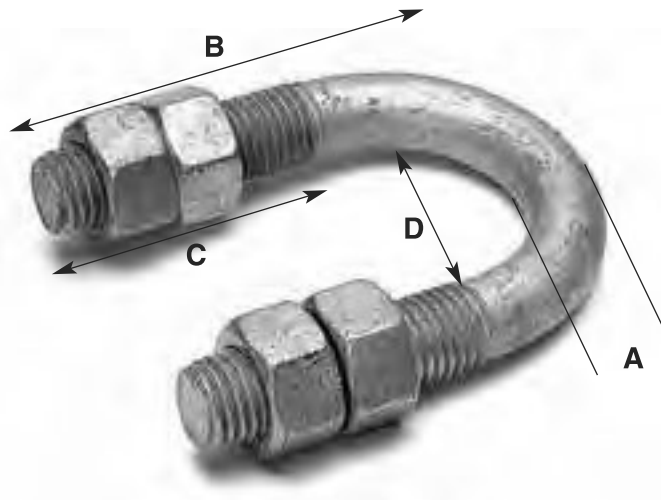

V6661



### Lag Bolts Gimlet Point

C.S.A. Standard Drawing No. S-1 except hexagon head instead of square. Fetter Drive available upon request on limited sizes, add suffix "LF".

Cat.No.	Dimensions	Std.Pkg.	Wt.-lbs./ C
<b>1/4" Diameter:</b>			
2514LG	1/4 x 2-1/2	100	4
314LG	1/4 x 3	100	5
<b>5/16" Diameter:</b>			
2556LG	5/16 x 2-1/2	100	6
356LG	5/16 x 3	100	7
<b>3/8" Diameter:</b>			
238LG	3/8 x 2	50	9
2538LG	3/8 x 2-1/2	50	10
338LG	3/8 x 3	50	11
3538LG	3/8 x 3-1/2	50	12
438LG	3/8 x 4	50	14
4538LG	3/8 x 4-1/2	50	15
538LG	3/8 x 5	50	16
638LG	3/8 x 6	50	18
<b>1/2" Diameter:</b>			
2512LG	1/2 x 2-1/2	50	17
312.LG	1/2 x 3	50	19
3512LG	1/2 x 3-1/2	50	22
412LG	1/2 x 4	50	25
4512LG	1/2 x 4-1/2	50	28
512LG	1/2 x 5	20	30
612LG	1/2 x 6	20	35
<b>5/8" Diameter:</b>			
458LG	5/8 x 4	25	38
558LG	5/8 x 5	25	46
658LG	5/8 x 6	25	54
758LG	5/8 x 7	25	62
858LG	5/8 x 8	25	70

Pilot point available upon request on limited sizes.  
 Other sizes available upon request.  
 Fetter drive available upon request on limited sizes.



338LG



# Bolts & Bolt Eyes

## SPOOL, BOLT EYES, ANGLE

### Spool Bolts

Used with spool insulators 355WSPG (not included). Flats on Collar provided for applying wrench.

Cat.No.	Diameter	L	L1	Std.Pkg.	Wt.-lbs./ C
858SB	5/8	13-1/2	8	50	180
1058SB	5/8	15-1/2	10	50	195
1258SB	5/8	17-1/2	12	20	210
1458SB	5/8	19-1/2	14	20	225

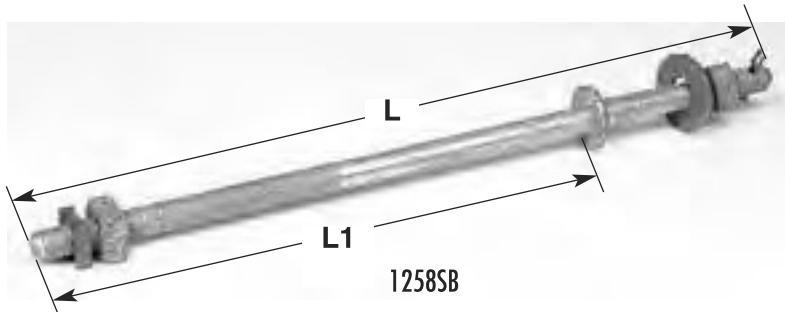

### Bolt Eye

For attachment to either or both ends of a double arming bolt.

Cat.No.	L	Slot	Std. Pkg.	Wt.-lbs./C
111BE	1	11/16	25	100
113BE	1	13/16	25	100



### Angle Thimble Eyelet

-Drop forged steel

-Bent at 45° angle

-Used to assemble upper end of guy on ground before raising it to the pole top.

Cat.No.	Bolt Dia. Inches	Strand Dia.Inches	Strength (lbs.)	Std. Pkg.	Wt.-lbs. (100 Pcs.)
111ATE	11/16	3/16 TO 1/2	12400	50	134
113ATE	13/16	3/16 TO 1/2	18300	50	128

